

ALUMINUM ELECTROLYTIC CAPACITORS · RADIAL TYPE

CD 282X EQ SERIES

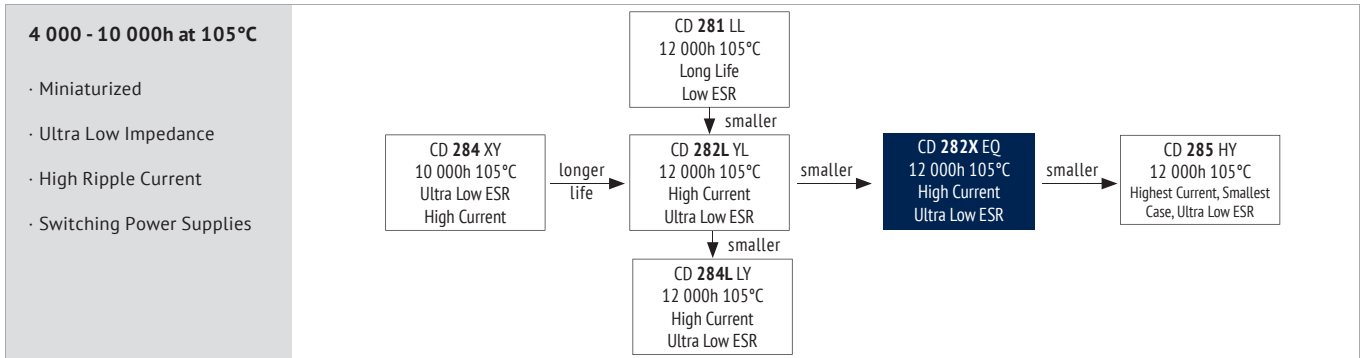

ITEM CHARACTERISTICS

Operating Temperature Range (°C)	-40 ~ +105
Voltage Range (V)	6,3 ~ 100
Capacitance Range (µF)	1 ~ 15 000
Capacitance Tolerance (20°C, 120Hz)	± 20%

! The usage at lower temperatures than indicated may be possible. Please contact the Jianghai Europe sales office for approval.

Leakage Current (µA) After 2 minutes at 20°C application of rated voltage, leakage current is not more than specified in table.

Stability at Low Temperature (Impedance Ratio at 120Hz)	Rated Voltage (V)	6,3	10	16	25	35	50	63	100
	Z _{-25°C} / Z _{+20°C}	4	3			2			
	Z _{-40°C} / Z _{+20°C}	8	6	4			3		

ITEM USEFUL LIFE LOAD LIFE ENDURANCE TEST SHELF LIFE

Lifetime	Ø 5:	6 000h	7 000h	> 250 000h	6,3~10V:	4 000h	5 000h	6,3~10V:	6 000h	7 000h	1 000h
	Ø 6,3-8:	8 000h	9 000h		6,3~10V:	6 000h	7 000h	6,3~10V:	8 000h	9 000h	
	Ø 10-18:	10 000h	12 000h		6,3~10V:	8 000h	10 000h	6,3~10V:	10 000h	12 000h	
Leakage Current	Not more than specified value				Not more than specified value		Not more than specified value		Not more than specified value		
Capacitance Change	Within ± 40% of initial value				Within ± 25% of initial value		Within ± 25% of initial value		Within ± 20% of initial value		
Dissipation Factor	Not more than 300% of specified value				Not more than 200% of specified value		Not more than 200% of specified value		Not more than 200% of specified value		
Condition:	U _R		U _R		U _R		U _R		U _R = 0		After test: U _R to be applied for 30 min > 24h before measurement
Applied Voltage	I _R		1,4 x I _R		I _R		I _R = 0		I _R = 0		
Applied Current	105°C		40°C		105°C		105°C		105°C		
Applied Temperature					IEC 60384						

MULTIPLIER FOR RIPPLE CURRENT (FREQUENCY COEFFICIENT)

Capacitance (µF)	Frequency			
	120Hz	1kHz	10kHz	100kHz
1	0,35	0,60	0,80	1,00
2,2 ~ 10	0,42	0,60	0,80	1,00
22 ~ 47	0,55	0,75	0,90	1,00
100 ~ 330	0,70	0,85	0,95	1,00
470 ~ 1 000	0,75	0,90	0,98	1,00
2 200 ~ 15 000	0,80	0,95	1,00	1,00

Multipliers for typical operating conditions.

MULTIPLIER FOR LIFETIME (LIFETIME DIAGRAM)

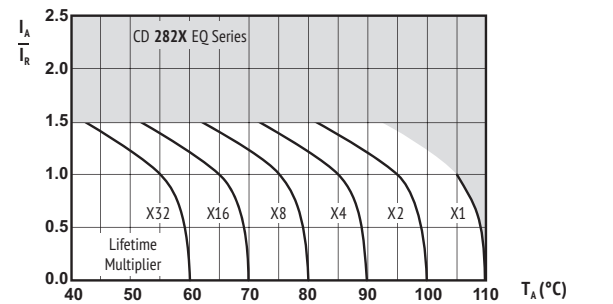

I_A = actual ripple current at 100kHz, I_R = rated ripple current at 100kHz, 105°C
Multiplier of Useful Life as a function of ambient temperature & ripple current load

ENVIRONMENTAL

The products are RoHS, WEEE and RECh compliant. The detailed version please see separate "Environmental Certificates" document or www.jianghai-europe.com

! SAFETY FACTOR

This diagram includes a safety margin. In many cases the allowed current capability/lifetime may be increased. For details and approvals please contact the Jianghai Europe sales office.





U _{RDC} (Surge Voltage) Code	C _R Rated Capacitance	ESR _{max} Equivalent Series Resistance	Z _{max} Max Impedance		tanδ Dissipation Factor	I _{leak} Leakage Current	I _{RAC} Rated Ripple Current	Size øD x L	ORDER CODE	
			20°C 120kHz	20°C 100kHz						20°C 100kHz
(V)	(µF)	(Ω)	(Ω)	(Ω)		(µA)	(mA _{RMS})	(mm)	Details: Page 5	
6,3 (7,2) 0J	100	2,92	0,900	3,60	0,22	7	150	5 x 11,5	ECR0JEQ101M◇◇△△0511	
	220	1,33	0,400	1,20	0,22	14	250	5 x 11,5	ECR0JEQ221M◇◇△△0511	
	330	0,884	0,220	0,870	0,22	21	340	6,3 x 11,5	ECR0JEQ331M◇◇△△0611	
	470	0,621	0,220	0,870	0,22	30	400	6,3 x 11,5	ECR0JEQ471M◇◇△△0611	
	1 000	0,292	0,130	0,520	0,22	63	640	8 x 11,5	ECR0JEQ102M◇◇△△0811	
	2 200	0,145	0,062	0,250	0,24	139	1300	10 x 16	ECR0JEQ222M◇◇△△1016	
	3 300	0,104	0,046	0,180	0,26	208	1400	10 x 20	ECR0JEQ332M◇◇△△1020	
	4 700	0,079	0,032	0,110	0,28	297	2230	12,5 x 25	ECR0JEQ472M◇◇△△1225	
	6 800	0,062	0,032	0,110	0,32	429	2230	12,5 x 25	ECR0JEQ682M◇◇△△1225	
	10 000	0,053	0,021	0,060	0,40	630	2930	16 x 25	ECR0JEQ103M◇◇△△1625	
	15 000	0,044	0,015	0,044	0,50	945	3610	16 x 35,5	ECR0JEQ153M◇◇△△1635	
10 (13) 1A	100	2,52	0,900	3,60	0,19	10	150	5 x 11,5	ECR1AEQ101M◇◇△△0511	
	220	1,15	0,400	1,20	0,19	22	250	5 x 11,5	ECR1AEQ221M◇◇△△0511	
	330	0,764	0,220	0,870	0,19	33	400	6,3 x 11,5	ECR1AEQ331M◇◇△△0611	
	470	0,536	0,220	0,870	0,19	47	400	6,3 x 11,5	ECR1AEQ471M◇◇△△0611	
	1 000	0,252	0,080	0,320	0,19	100	865	10 x 12,5	ECR1AEQ102M◇◇△△1012	
	2 200	0,127	0,046	0,180	0,21	220	1400	10 x 20	ECR1AEQ222M◇◇△△1020	
	3 300	0,092	0,041	0,140	0,23	330	1900	12,5 x 20	ECR1AEQ332M◇◇△△1220	
	4 700	0,071	0,032	0,110	0,25	470	2230	12,5 x 25	ECR1AEQ472M◇◇△△1225	
	6 800	0,057	0,021	0,060	0,29	680	2930	16 x 25	ECR1AEQ682M◇◇△△1625	
	10 000	0,049	0,019	0,056	0,37	1000	3450	16 x 31,5	ECR1AEQ103M◇◇△△1631	
	16 (20) 1C	47	4,52	0,400	1,20	0,16	8	250	5 x 11,5	ECR1CEQ470M◇◇△△0511
100		2,13	0,400	1,20	0,16	16	250	5 x 11,5	ECR1CEQ101M◇◇△△0511	
220		0,965	0,220	0,870	0,16	36	400	6,3 x 11,5	ECR1CEQ221M◇◇△△0611	
330		0,643	0,220	0,870	0,16	53	400	6,3 x 11,5	ECR1CEQ331M◇◇△△0611	
470		0,452	0,130	0,520	0,16	76	640	8 x 11,5	ECR1CEQ471M◇◇△△0811	
1 000		0,212	0,062	0,250	0,16	160	1210	10 x 16	ECR1CEQ102M◇◇△△1016	
2 200		0,109	0,041	0,140	0,18	352	1900	12,5 x 20	ECR1CEQ222M◇◇△△1220	
3 300		0,080	0,032	0,110	0,20	528	2230	12,5 x 25	ECR1CEQ332M◇◇△△1225	
4 700		0,062	0,021	0,060	0,22	752	2930	16 x 25	ECR1CEQ472M◇◇△△1625	
6 800		0,051	0,019	0,056	0,26	1088	3450	16 x 31,5	ECR1CEQ682M◇◇△△1631	
25 (32) 1E		33	5,63	0,400	1,20	0,14	9	250	5 x 11,5	ECR1EEQ330M◇◇△△0511
	47	3,96	0,400	1,20	0,14	12	250	5 x 11,5	ECR1EEQ470M◇◇△△0511	
	100	1,86	0,400	1,20	0,14	25	250	5 x 11,5	ECR1EEQ101M◇◇△△0511	
	220	0,844	0,220	0,870	0,14	55	400	6,3 x 11,5	ECR1EEQ221M◇◇△△0611	
	330	0,563	0,130	0,520	0,14	83	640	8 x 11,5	ECR1EEQ331M◇◇△△0811	
	470	0,395	0,080	0,320	0,14	118	865	10 x 12,5	ECR1EEQ471M◇◇△△1012	
	1 000	0,186	0,046	0,180	0,14	250	1400	10 x 20	ECR1EEQ102M◇◇△△1020	
	2 200	0,096	0,032	0,110	0,16	550	2230	12,5 x 25	ECR1EEQ222M◇◇△△1225	
	3 300	0,072	0,021	0,060	0,18	825	2930	16 x 25	ECR1EEQ332M◇◇△△1625	
	4 700	0,056	0,019	0,056	0,20	1175	3450	16 x 31,5	ECR1EEQ472M◇◇△△1631	
	35 (44) 1V	33	4,83	0,400	1,20	0,12	12	250	5 x 11,5	ECR1VEQ330M◇◇△△0511
47		3,39	0,400	1,20	0,12	17	250	5 x 11,5	ECR1VEQ470M◇◇△△0511	
100		1,60	0,220	0,870	0,12	35	400	6,3 x 11,5	ECR1VEQ101M◇◇△△0611	
220		0,723	0,130	0,520	0,12	77	640	8 x 11,5	ECR1VEQ221M◇◇△△0811	
330		0,482	0,080	0,320	0,12	116	865	10 x 12,5	ECR1VEQ331M◇◇△△1012	
470		0,339	0,062	0,250	0,12	165	1210	10 x 16	ECR1VEQ471M◇◇△△1016	
1 000		0,159	0,041	0,140	0,12	350	1900	12,5 x 20	ECR1VEQ102M◇◇△△1220	
2 200		0,084	0,021	0,060	0,14	770	2930	16 x 25	ECR1VEQ222M◇◇△△1625	
3 300		0,064	0,019	0,056	0,16	1155	3450	16 x 31,5	ECR1VEQ332M◇◇△△1631	
50 (63) 1H		1,0	132	4,00	8,00	0,10	3	30	5 x 11,5	ECR1HEQ010M◇◇△△0511
		2,2	60,3	2,50	6,00	0,10	3	43	5 x 11,5	ECR1HEQ2R2M◇◇△△0511
	3,3	40,2	2,20	5,60	0,10	3	53	5 x 11,5	ECR1HEQ3R3M◇◇△△0511	
	4,7	28,3	1,90	5,00	0,10	3	88	5 x 11,5	ECR1HEQ4R7M◇◇△△0511	
	10	13,3	1,50	4,00	0,10	5	100	5 x 11,5	ECR1HEQ100M◇◇△△0511	
	22	6,03	0,700	2,80	0,10	11	180	5 x 11,5	ECR1HEQ220M◇◇△△0511	
	33	4,02	0,700	2,80	0,10	17	250	5 x 11,5	ECR1HEQ330M◇◇△△0511	
	44	3,02	0,300	1,20	0,10	22	295	6,3 x 11,5	ECR1HEQ470M◇◇△△0611	
	100	1,33	0,170	0,680	0,10	50	555	8 x 11,5	ECR1HEQ101M◇◇△△0811	
	220	0,603	0,084	0,340	0,10	110	1050	10 x 16	ECR1HEQ221M◇◇△△1016	





U_{RDC} (Surge Voltage) Code	C_R Rated Capacitance	ESR_{max} Equivalent Series Resistance 20°C 120Hz	Z_{max} Max Impedance 20°C 100kHz	Z_{max} Max Impedance -10°C 100kHz	$\tan\delta$ Dissipation Factor 20°C 120Hz	I_{leak} Leakage Current	I_{RAC} Rated Ripple Current 105°C 100kHz	Size $\varnothing D \times L$	ORDER CODE ◇◇ = pin style & length △△ = pitch code Details: Page 5
(V)	(μF)	(Ω)	(Ω)	(Ω)		(μA)	(mA _{RMS})	(mm)	
50 (63) 1H	330	0,402	0,060	0,240	0,10	165	1220	10 x 20	ECR1HEQ331M◇◇△△1020
	470	0,282	0,045	0,150	0,10	235	1660	12,5 x 20	ECR1HEQ471M◇◇△△1220
	1 000	0,133	0,032	0,096	0,10	500	2730	16 x 25	ECR1HEQ102M◇◇△△1625
	2 200	0,072	0,019	0,057	0,12	1100	3150	16 x 35,5	ECR1HEQ222M◇◇△△1635
63 (79) 1J	10	12,0	0,880	3,50	0,09	7	173	5 x 11,5	ECR1JEQ100M◇◇△△0511
	22	5,43	0,880	3,50	0,09	14	173	5 x 11,5	ECR1JEQ220M◇◇△△0511
	33	3,62	0,350	1,40	0,09	21	278	6,3 x 11,5	ECR1JEQ330M◇◇△△0611
	47	2,54	0,350	1,40	0,09	30	278	6,3 x 11,5	ECR1JEQ470M◇◇△△0611
	100	1,20	0,150	0,600	0,09	63	725	10 x 12,5	ECR1JEQ101M◇◇△△1012
	220	0,543	0,078	0,310	0,09	139	1200	10 x 20	ECR1JEQ221M◇◇△△1020
	330	0,362	0,060	0,190	0,09	208	1570	12,5 x 20	ECR1JEQ331M◇◇△△1220
	470	0,254	0,043	0,140	0,09	297	1990	12,5 x 25	ECR1JEQ471M◇◇△△1225
	1 000	0,119	0,032	0,096	0,09	630	2730	16 x 25	ECR1JEQ102M◇◇△△1625
	100 (125) 2A	1,0	106	4,50	15,0	0,08	3	20	5 x 11,5
2,2		48,3	3,00	13,0	0,08	3	30	5 x 11,5	ECR2AEQ2R2M◇◇△△0511
3,3		32,2	2,70	11,0	0,08	4	40	5 x 11,5	ECR2AEQ3R3M◇◇△△0511
4,7		22,6	2,50	10,0	0,08	5	65	5 x 11,5	ECR2AEQ4R7M◇◇△△0511
10		10,7	0,570	2,30	0,08	10	267	6,3 x 11,5	ECR2AEQ100M◇◇△△0611
22		4,83	0,570	2,30	0,08	22	267	6,3 x 11,5	ECR2AEQ220M◇◇△△0611
33		3,22	0,360	1,40	0,08	33	462	8 x 11,5	ECR2AEQ330M◇◇△△0811
47		2,26	0,250	1,00	0,08	47	585	8 x 16	ECR2AEQ470M◇◇△△0816
100		1,07	0,120	0,520	0,08	100	1040	10 x 20	ECR2AEQ101M◇◇△△1020
220		0,482	0,060	0,230	0,08	220	1620	12,5 x 25	ECR2AEQ221M◇◇△△1225
330		0,322	0,044	0,160	0,08	330	2210	16 x 25	ECR2AEQ331M◇◇△△1625





ORDER CODE FOR RADIAL CAPACITORS

EC	R	2G	QX	221	M	LL	50	1012	-	-	JExxxxx									
Techno-logy	Terminal Type	Rated Voltage Code	Series Code	Capacitance Code	Capacitance Tolerance	Terminal Style	Terminal / Pitch	Dimension (mm)	Material Code	Rubber Type	for Specials only									
EC Electrolytic Capacitor	Radial R	6,3V	0J	CD 110	PT	0,1	0R1	±20%	M	Taped	FF	2,0mm	20	4x7	0407	Standard	-	Standard	-	
		10V	1A	CD 11GL	GL	0,47	R47	±10%	K	Long Lead	LL	2,5mm	25	5x11,5	0511	PVC	V	Flat Rubber	F	
		16V	1C	CD 261	LK	1,0	010	+30 / -10%	Q	Cut 5,0mm	CB	3,5mm	35	10x20	1020	PET	E	Stand-Off	S	
		20V	1D	CD 261L	DE	2,2	2R2	+20 / -0%	R	Cut 4,5mm	CC	5,0mm	50	12,5x25	1225					
		25V	1E	CD 261X	QX	100	101	±15%	L	Cut 4,0mm	CD	7,5mm	75							
		35V	1V	CD 263	BK	1000	102	+20 / -10%	V	Cut 3,5mm	CE	10,0mm	10							
		40V	1G	CD 269	PH	10 000	103	■ = preferred		Cut 3,0mm	CF	12,5mm	12							
		50V	1H	CD 269L	HL															
		63V	1J	CD 281	LL															
		80V	1K	CD 281L	LH															
		100V	2A	CD 282L	YL															
		125V	2B	CD 282X	EQ															
		160V	2C	CD 284	XY															
		180V	2K	CD 284L	LY															
		200V	2D	CD 285	HY															
		250V	2E	CD 287	GC															
		350V	2V	CD 28L	QL															
		385V	2J																	
		400V	2G																	
		415V	2P																	
		420V	2X																	
		450V	2W																	
		500V	2H																	
550V	2Y																			
575V	2Z																			
600V	2S																			
630V	J2																			

On request:
Alternative lead forms
(keyed polarity, 90° bended, others)

Packaging:
Taped: ammopack
Long lead & cut: bulk





DIMENSIONS FOR LOOSE, LONG-LEAD TYPE (BULK)

· ORDER CODE: LL

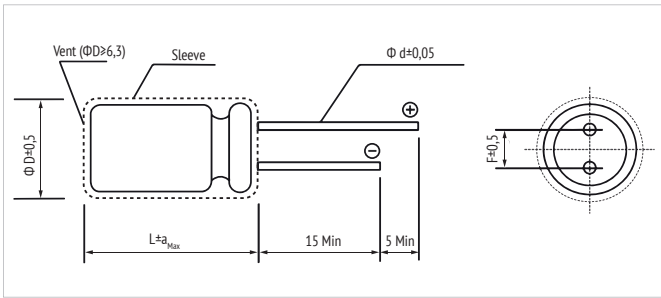

L	L ≤ 7					L ≥ 11									
	3	4	5	6,3	8	5	6,3	8	10	12,5	16	18	20	22	25
Ø D	3	4	5	6,3	8	5	6,3	8	10	12,5	16	18	20	22	25
F	1,0	1,5	2,0	2,5	3,5	2,0	2,5	3,5	5,0	7,5		10,0		12,5	
Ø d	0,4	0,45		0,5		0,6		0,8		1,0					
a _{Max}	1,0		2,0				2,5								

For diameter 20 pitch 7,5 or 10.

in mm

DIMENSIONS FOR LOOSE, SHORT CUT LEADS (BULK)

· ORDER CODE: CC (CB, CD, CE, CF)

STRAIGHT LEAD

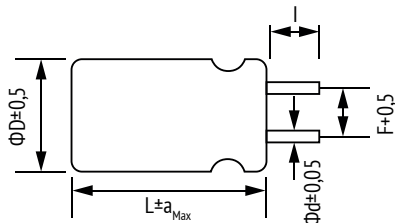

BENDE LEAD

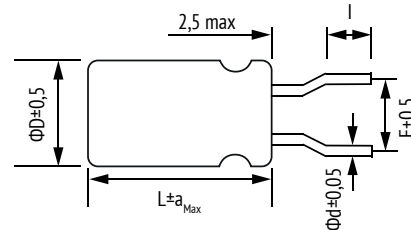

Code	CB	CC	CD	CE	CF
I	5,0 ± 0,5	4,5 ± 0,5	4,0 ± 0,5	3,5 ± 0,5	3,0 ± 0,5

■ = preferred

in mm

EXAMPLE OF ALTERNATIVE BENDINGS

· ORDER CODE: WS

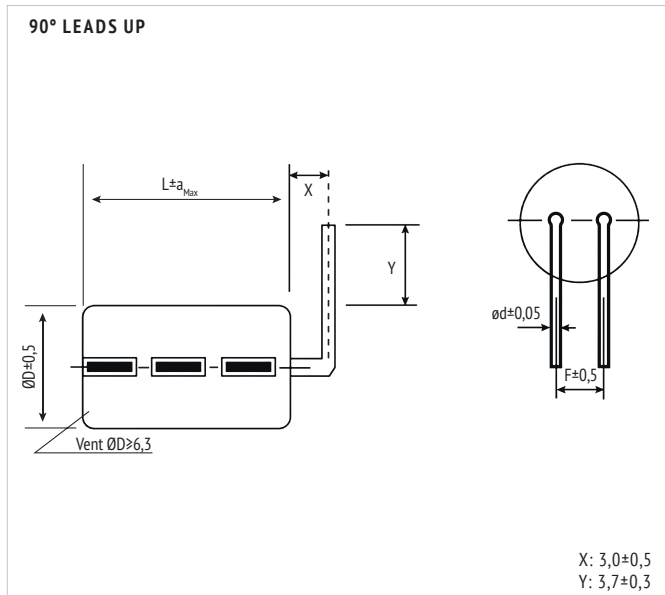

· ORDER CODE: WX

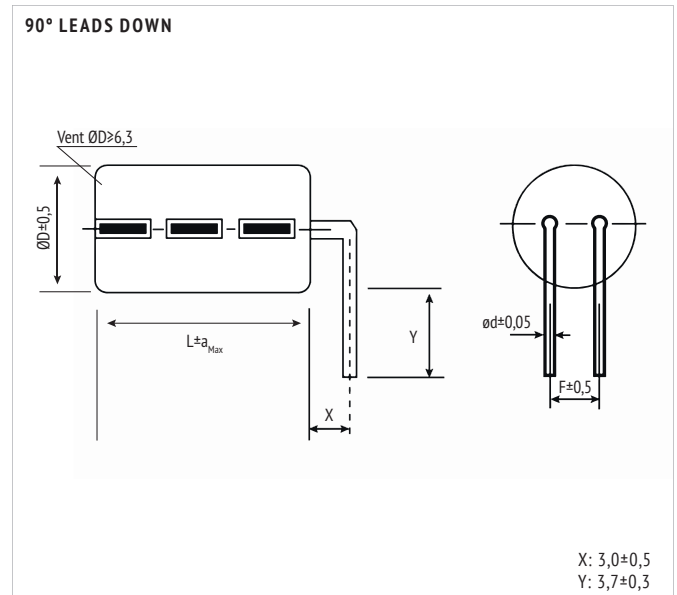



DIMENSIONS FOR AMMOPACK TAPING FOR ELECTROLYTIC CAPACITORS

· ORDER CODE: FF (FD)

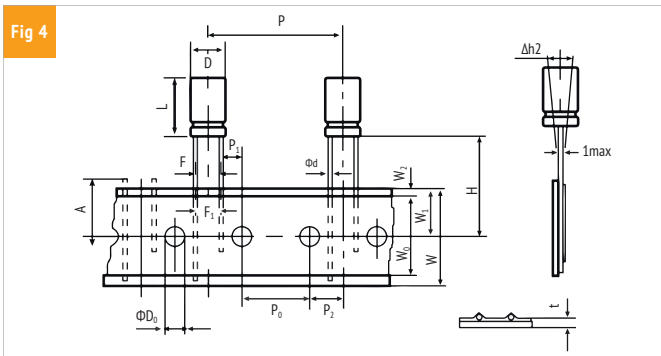
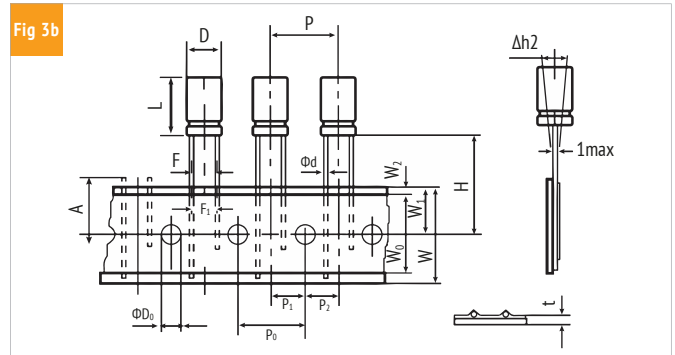
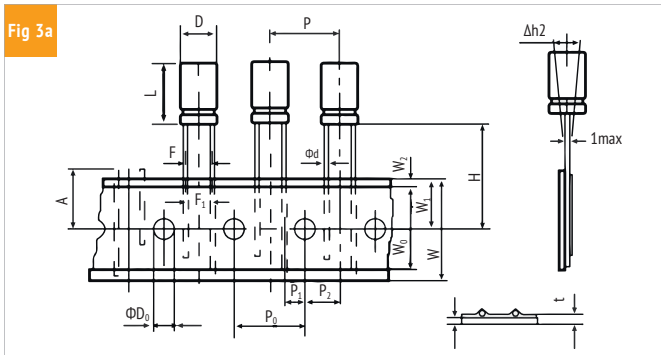
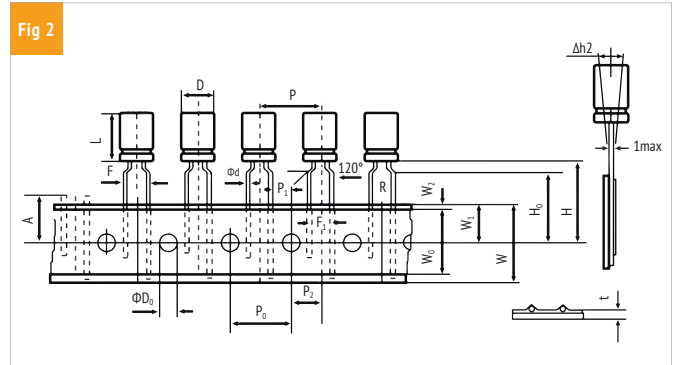
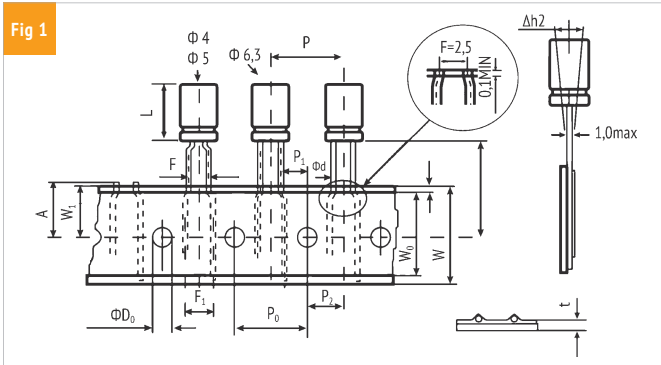

OTHER TAPING STYLES AVAILABLE ON REQUEST.

ITEM	D	L	Ød	P	P ₀	P ₁	P ₂	F	F ₁	W	W ₀	W ₁	W ₂	H	H ₀	A	ØD ₀	Δh ₂	t	Fig.	Taping Code
ToL.	± 0,5	± 2,0	± 0,05	± 1,0	± 0,2	± 0,5	± 1,0	+0,8 -0,2	± 1,0	± 0,5	min	± 0,5	max	+0,75 -0,5	± 0,5	max	± 0,5	max	± 0,2		
Nominal	4	7	0,45	12,7	12,7	5,1	6,35	2,5	3,5	18,0	10,0	9,0	1,5	18,5	-	11,0	4,0	1,0	0,7	1	FF
						3,85		5	5					17,5	16,0					2	FF
	5	7	0,45	12,7	12,7	5,1	6,35	2,5	3,5	18,0	10,0	9,0	1,5	18,5	-	11,0	4,0	1,0	0,7	1	FF
						3,85		5	5					17,5	16,0					2	FF
	5	11,5-15	0,5	12,7	12,7	5,1	6,35	2,5	3,5	18,0	10,0	9,0	1,5	18,5	-	11,0	4,0	1,0	0,7	1	FF
						3,85		5	5					16,0	16,0					2	FF
	6,3	7	0,45	12,7	12,7	5,1	6,35	2,5	3,5	18,0	10,0	9,0	1,5	18,5	-	11,0	4,0	1,0	0,7	1	FF
						3,85		5	5					17,5	16,0					2	FF
	6,3	11,5-15	0,5	12,7	12,7	5,1	6,35	2,5	3,5	18,0	10,0	9,0	1,5	18,5	-	11,0	4,0	1,0	0,7	1	FF
						3,85		5	5					16,0	16,0					2	FF
	8	11,5-20	0,6	12,7	12,7	4,6	6,35	3,5	3,5	18,0	10,0	9,0	1,5	18,5	-	11,0	4,0	1,0	0,7	3a	FF
						3,85		5	5					20,0	16,0					2	FF
10	12,5-36	0,6	12,7	12,7	3,85	6,35	5	5	18,0	10,0	9,0	1,5	18,5	-	11,0	4,0	1,0	0,7	3b	FF	
12,5	15-36	0,6	15	15	5,0	7,5	5	5	18,0	12,0	9,0	1,5	18,5	-	11,0	4,0	1,0	0,7	3b	FF	
			25,4	12,7	3,85	6,35															
16	15-31,5	0,8	30	15	3,75	7,5	7,5	7,5	18,0	12,0	9,0	1,5	18,5	-	11,0	4,0	1,0	0,7	4	FD	
18	15-25,5	0,8	30	15	3,75	7,5	7,5	7,5	18,0	12,0	9,0	1,5	18,5	-	11,0	4,0	1,0	0,7	4	FD	

Other taping styles available on request

in mm





**RADIAL
6,3V
~
100V**

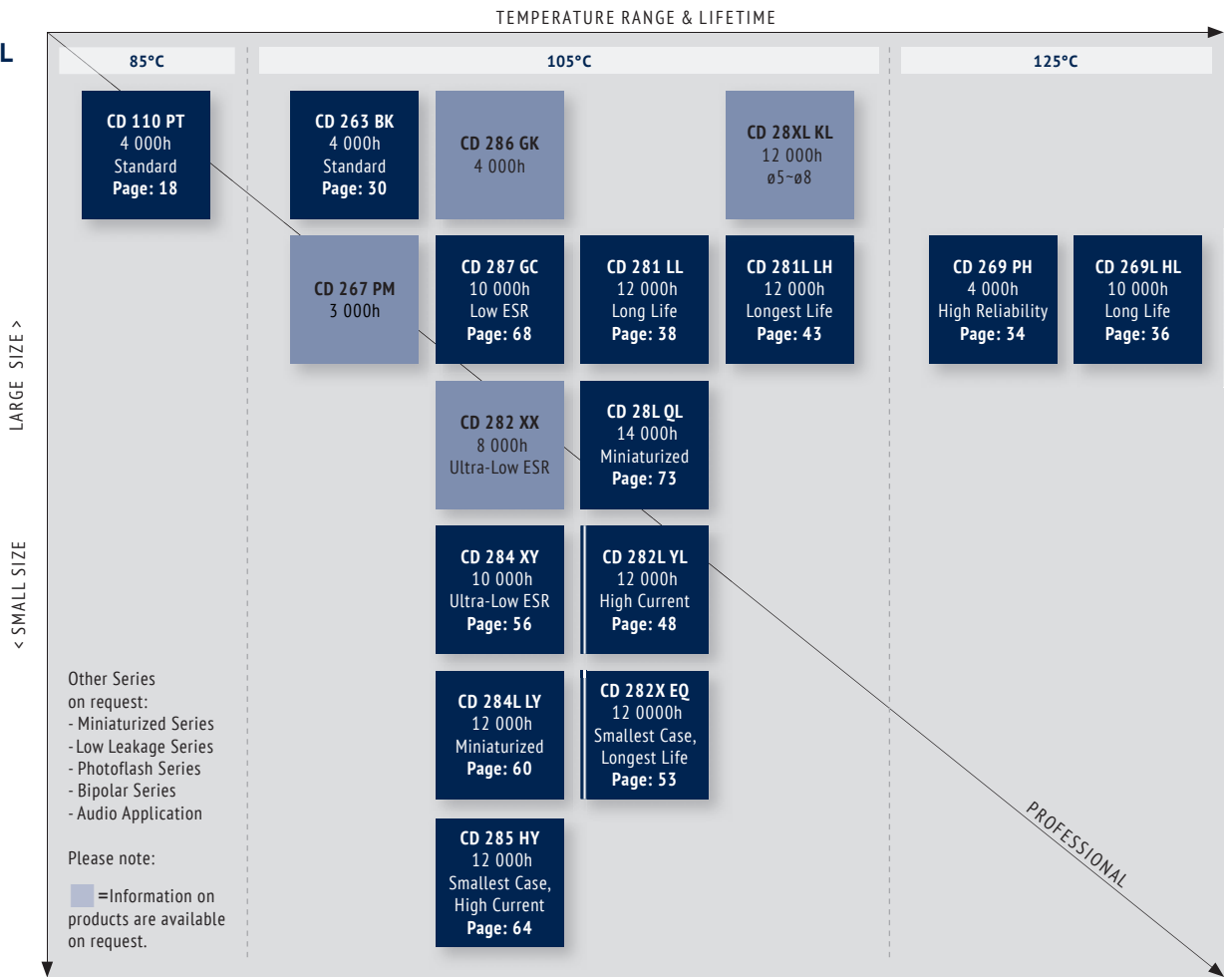

**RADIAL
160V
~
550V**

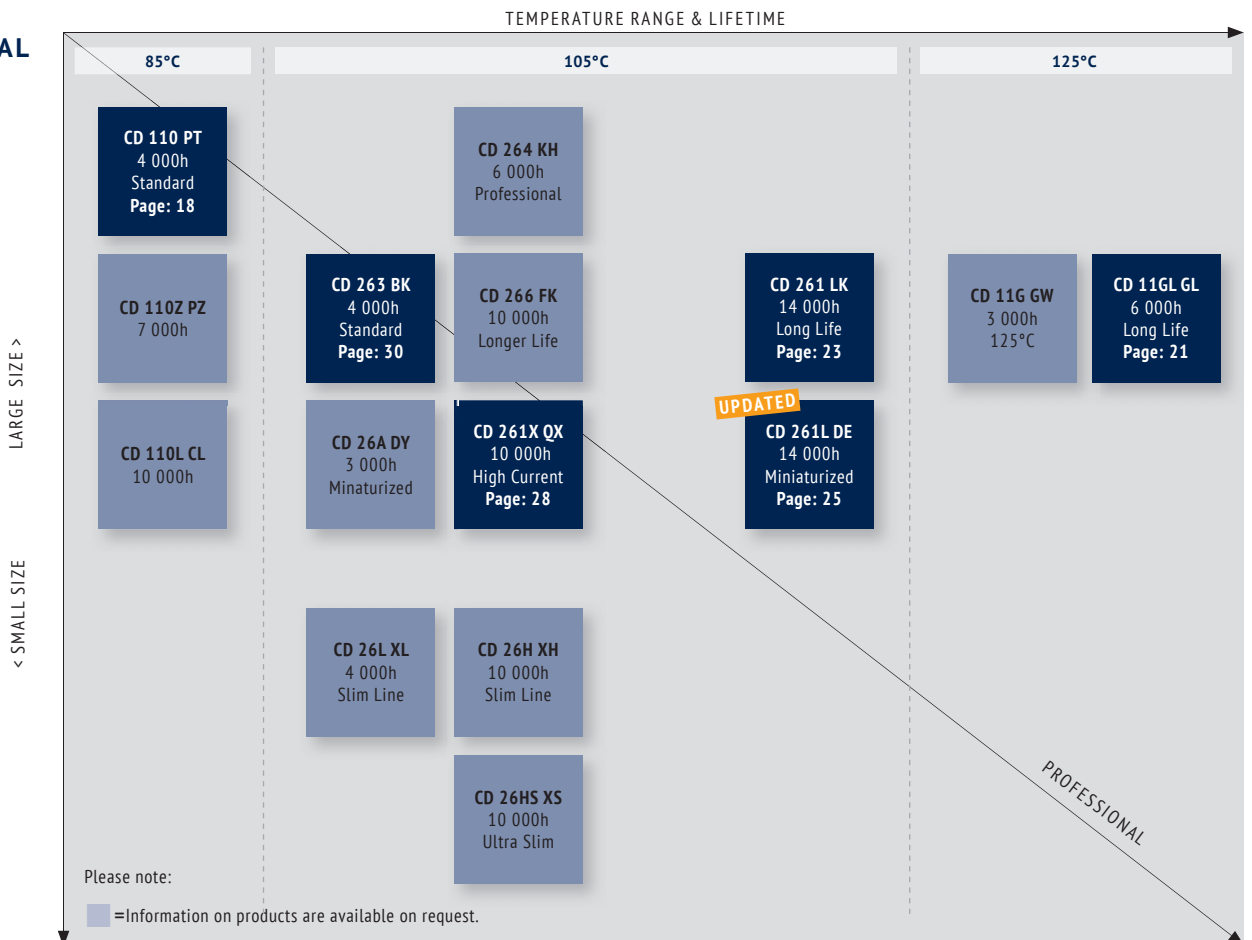



LIFETIME ESTIMATION OF ALUMINUM ELECTROLYTIC CAPACITORS FROM JIANGHAI

To estimate the Lifetime of a non-solid Aluminum Electrolytic Capacitor from Jianghai, the following formulas can be utilized. The Lifetime depends mainly on the ambient temperature, the ripple current and, within certain limits, the operating voltage applied. Other parameters may also affect the Lifetime. Moreover, L_0 can be interpreted in many different ways, which has a fundamental influence on the numerical result. Jianghai offers a high transparency by publishing the different typical definitions of Lifetimes in each datasheet. Lifetime estimations are approximations by nature. Please let JIANGHAI EUROPE confirm any result before using it. The formulas given here do not constitute part of a contract nor of a specification. The formulas do not cover additional aging effects of certain electrolytic systems or other chemical effects. Also the dimensions of the components may have an effect. Forced cooling or other additional cooling-methods have a strong impact on the Lifetime and are not covered by the formulas as defined. For the estimation and interpretation of Lifetime, a close collaboration with JIANGHAI EUROPE is strongly advised.

STRUCTURAL FORMULA

$$L = L_0 \cdot K_T \cdot K_R \cdot K_V$$

WHERE:

- L Total Lifetime
- L_0 Lifetime under Nominal Load at Upper Category Temperature (see catalogue)
- K_T Temperature Factor
- K_R Ripple Current Factor
- K_V Voltage Factor

K_T TEMPERATURE FACTOR

Aluminum Electrolytic Capacitors follow roughly the 10 K rule of Arrhenius. It is possible to estimate the Lifetime by rule of thumb: When the operational temperature is reduced by 10 K, the Lifetime will double. The formula for K_T in detail is:

$$K_T = 2^{\frac{T_0 - T_A}{10K}}$$

WHERE:

- T_0 Rated Temperature
- T_A Ambient Temperature

K_R RIPPLE CURRENT FACTOR

To estimate the influence of ripple current on lifetime, Jianghai uses a safety factor K_i . Under certain conditions this value can be set to $K_i=2$, which is prolonging the lifetime. Please contact Jianghai Europe for details and approval.

$$K_R = K_i^A \frac{\Delta T_0}{10K}$$

WITH:

$$A = 1 - \left(\frac{I_A}{I_R} \right)^2$$

WHERE:

- I_A Actual Rated Ripple Current
- I_R Ripple Current at Upper Category Temperature (databook value)
- ΔT_0 Core Temperature Rise of the capacitor (typically 3,5 ~ 5 K for $T_0 = 105^\circ\text{C}$ and 3,5 ~ 10K for $T_0 = 85^\circ\text{C}$, see databook value)
- K_i Basis, typically defined as

$T_0 = 105^\circ\text{C}$	$I_A > I_R$:	$K_i=4$
	$I_A \leq I_R$:	$K_i=2$
$T_0 = 85^\circ\text{C}$		$K_i=2$



Remark: Safety Factor K_i may be set as $K_i=2$ under certain defined conditions. Please contact Jianghai Europe for approval.

K_V VOLTAGE FACTOR

For Radial Electrolytic Capacitors, this part of the formula has no impact ($K_V = 1$). But for some bigger capacitors like Snap-In and Screw-Terminal types with rated voltages above 160V, the operating voltage will affect their Lifetime. It is expressed as follows:

FOR:

$$0,6 \leq \frac{U_A}{U_R} \leq 1$$

$$K_V = \left(\frac{U_A}{U_R} \right)^{-2,5}$$

WHERE:

- U_A Actual Operating Voltage
- U_R Rated Voltage





FOR:

$$0 < \frac{U_A}{U_R} < 0,6$$

$$K_V = 3,59$$

FOR:

$$\frac{U_A}{U_R} > 1 \text{ not allowed}$$

$$K_V = 1$$

FOR: Radial Capacitors or $U_R \leq 160V$

$$K_V = 1$$

FREQUENCY CORRECTION FACTORS:

If the actual Ripple Currents are not given at the same frequency like I_{σ} , correction factors need to be applied.

$$I_A = \sqrt{\left(\frac{I_{f1}}{F_{f1}}\right)^2 + \left(\frac{I_{f2}}{F_{f2}}\right)^2 + \dots + \left(\frac{I_{fn}}{F_{fn}}\right)^2}$$

JIANGHAI ELECTROLYTIC CAPACITOR LIFETIME

ESTIMATION FORMULA (incl. Safety Factors):

$$L = L_0 \cdot 2^{\frac{T_0 - T_A}{10K}} \cdot K_i \left[1 - \left(\frac{I_A}{I_R}\right)^2 \right]^{\frac{\Delta T_0}{10K}} \cdot \underbrace{\left(\frac{U_A}{U_R}\right)^{-n}}_{K_V}$$

WITH TYPICAL VALUES:

$$T_0 = 105^\circ C \quad I_A > I_R : K_i = 4$$

$$I_A \leq I_R : K_i = 2$$

$$T_0 = 85^\circ C \quad K_i = 2$$

$\Delta T_0 =$ depending on the series: 3,5~10K,
see databook value

$$0,6 \leq \frac{U_A}{U_R} \leq 1 \rightarrow n = 2,5$$

$$0 < \frac{U_A}{U_R} < 0,6 \rightarrow K_V = \left(\frac{U_A}{U_R}\right)^{-n} = 3,59$$

For $U_R \leq 160V$, Radial and

$$\frac{U_A}{U_R} > 1 \rightarrow K_V = 1$$

HANDLING PRECAUTIONS FOR ALUMINUM ELECTROLYTIC CAPACITORS FROM JIANGHAI

WARNING

JIANGHAI is not liable for any extent of possible injuries or damages to persons or things, of any kind, caused by the improper application of and/or operating conditions harmful to electrolytic capacitors. Misapplications which may cause failures include, but are not limited to: ripple current or peak current or voltage above specification, operating voltage above surge voltage specified, temperature exposure outside the specified operating temperature range. Examples of harmful operating conditions comprise, but are not limited to: unusual storage or transport temperatures, excessive and/or rapid changes of ambient temperature or humidity, heavy mechanical shock or vibration, corrosive and abrasive particles in the ambient (cooling) air, conducting dust in the ambient (cooling) air, oil or water vapor or corrosive substances, explosive gas or dust, operation under extremely high or low ambient pressure conditions (below or above sea level), superimposed radio frequency voltages, radioactivity. In case of doubt about the impact of operating conditions on capacitor performance, please contact JIANGHAI.

PERSONAL SAFETY

Electrical or mechanical misapplication of electrolytic capacitors may be hazardous. Personal injury or property damage may result from explosion of a capacitor or from the expulsion of electrolyte due to mechanical disruption or the release of a safety vent of a capacitor. In case of injury or skin or eye exposure to electrolyte, immediately seek professional medical advice. Before using electrolytic capacitors in any application, please read these Handling Precautions, familiarizing thoroughly with the information contained herein. Please check before using any of our electrolytic capacitors if these components fulfill the requirements of your application and that warnings and instructions for use are followed.

WARRANTY

The information contained in this catalogue does not form part of any quotation or contract, is believed to be accurate, reliable and up to date. Quality data are based on the statistical evaluations of a large quantity of parts and do not constitute a guarantee in a legal sense. However, agreement on these specifications does mean that the customer may claim for replacement of individual defective capacitors within the terms of delivery. We will not assume any liability beyond the replacement of defective components. This applies in particular to any consequential damage caused by component failure. Furthermore it must be taken into consideration that the figures stated for lifetime, failure rates and outlier percentages refer to the average production status and are therefore to be understood as mean values (statistic expectations) for a large number of delivery lots of identical capacitors. These figures are based on application experience and data obtained from preceding tests under normal conditions, or – for purpose of accelerated aging – more severe conditions. JIANGHAI reserves the right to change these specifications without prior notice. Any application information given is advisory and does not form part of any specification. The products are not primarily designed for use in life support applications, devices or systems where malfunction of these products can reasonably be expected to result in personal injury. JIANGHAI customers using or selling these products for use in such applications without prior written consent of JIANGHAI do so at their own risk and agree fully to indemnify JIANGHAI for any damage resulting from such improper use or sale. This version of the catalogue supersedes all previous versions. Latest versions of datasheets can be found on our homepage: www.jianghai-europe.com. For more details on precautions and guidelines for aluminum electrolytic capacitors, please refer to CENELEC Technical Report CLC/TR 50454:2008 E, "Guide for the application of aluminum electrolytic capacitors".

POLARITY

Electrolytic capacitors are polar and shall never be used with incorrect polarity, as there is a possible danger of shorting or destruction.

RATED VOLTAGE U_R

The rated voltage is marked on the capacitor and defined in the datasheets as U_R . This voltage should never be exceeded and is the maximum peak voltage including any ripple voltages allowed to avoid a shortening of the lifetime or damage of the capacitor. When a ripple current is applied to the capacitor, the sum of the peak ripple voltage and bias DC voltage shall never exceed the rated voltage. It might be necessary to lower the maximum allowed bias DC voltage, when certain ripple currents are applied to the capacitor.

SURGE VOLTAGE

Maximum voltage, which may be applied to the capacitor for short periods of time: max. 1000 cycles of 30 sec. per 6 min., max. 5 pulses per hour. Capacitance drift +/- 15% max.

REVERSE VOLTAGE

Reverse voltages or voltages < 0V are not allowed.





RECOVERY VOLTAGE

Electric potential between the positive and negative terminal may exist as a result of dielectric absorption. Please take action that this load does not damage other devices or scare workers during the production process (sparks possible). If needed please discharge the capacitor through a 1kΩ resistor.

TEMPERATURE RANGE

Use electrolytic capacitors only within the specified operating temperature range.

OVER-CURRENT

Currents exceeding the rated ripple currents should be avoided.

RIPPLE CURRENT/VOLTAGE

The combined value of DC voltage and peak AC voltage (due to ripple current) shall not exceed the rated voltage and shall never be < 0V. Use of aluminum electrolytic capacitors under ripple current with wide amplitudes is equivalent to rapid charge-discharge operation.

RAPID CHARGING/DISCHARGING

Rapid charging/discharging generates severe heat and gas may be emitted which may lead to explosion. Consult JIANGHAI about specially designed capacitors suitable for such kind of applications. Example: Servo Drive Application

BALANCING RESISTORS

Balancing resistors should be utilized if capacitors are used in serial connection. Please choose low-tolerance resistors to limit voltage drift.

CHARGE-DISCHARGE PROOF

JIANGHAI capacitors are charge-discharge proof, which means that 10⁶ switching cycles will cause capacitance reduction of less than 10%.

LIFETIME

There are many different lifetime definitions known without any true standard definition. Take special care when capacitors are compared that the capacitors fulfill the needed requirements. JIANGHAI publishes all conditions to be as transparent as possible. In the case of lifetime tests with additional ripple currents, the bias DC voltage must be reduced, so that the sum of bias DC voltage and the peak of the ripple voltage does not exceed the Rated Voltage U_R .

Load life: Period of time, during which the technical parameters of all capacitors stay within the given limits. JIANGHAI defines this without allowing for outliers.

Useful life: Defined like load life, but with a larger range of parameter change.

Endurance test: IEC 60384-4 defines the acceptable drift criteria of electrical parameters after the endurance tests (continuous voltage test).

Shelf Life: Definition of time with acceptable drift of capacitor parameters after storage at upper category temperature without load.

VIBRATION AND MECHANICAL STRESS

Capacitors are sensitive to vibration and mechanical forces applied on the leads. Do not use capacitors, which have been dropped onto a rigid surface.

INSULATION

If any defect of the sleeve is visible, the component should not be used – the same holds for any kind of visible damage. A capacitor should be electrically isolated from the following parts: aluminum case, cathode lead wire, anode lead wire and circuit pattern, and auxiliary terminal of snap-in type. The sleeve is not recognized as an isolator and therefore the standard capacitor should not be used in a place where insulation function is needed. Please contact JIANGHAI if a higher grade of insulation is required.

ENVIRONMENTAL CONDITIONS

Avoid direct contact with water, salt solution, oil, dewing conditions. Halogens generally, especially fumigation treatment with bromides and flame retardant agents containing halogens must be avoided. Avoid exposing to direct sunshine, ozone, ultraviolet rays and x-ray radiation. Air Pressure: Max. 150kPa, min. 8kPa. For usage >2000m altitude above sea level current deratings might be necessary. No heavy air pressure changes are allowed. Do not use or store in an environment containing any hazardous gas (e.g., hydrogen sulphide, sulphurous acid, nitrous acid, chlorine, ammonia, bromine, methyl bromide, other halogens) or acidic or alkaline solutions.

STORAGE

Temperature 5 to 35°C, relative humidity below 75%. Electrolytic capacitors may accumulate charge naturally during storage. In this case discharge through a 1kOhm resistor before use (Recovery voltage). Leakage current may be increased after long storage time. In this case the capacitor should be subjected to the rated voltage treatment through a 1kOhm resistor before use for 1 hour, then it should be discharged through a resistor of about 1 Ohm/Volt. Storage times above 1 year should be avoided or rated voltage treatment may be necessary. In accordance to IEC 60384-4 electrolytic capacitors are subject to a reforming process before acceptance testing. Rated voltage is applied via a series resistance (100Ω: $U_R \leq 100VDC$, 1kΩ: $U_R > 100VDC$).

SOLDERING

Soldering conditions (temperature, times) should be within specified conditions, especially for SMD components. Avoid high soldering temperatures as this may reduce lifetime or damage the capacitor. Do never dip the capacitor body into molten solder. Flux should not be adhered to the capacitor's body but only to its terminals. For details and different methods please contact us.

GLUEING, CLEANING AND COATING

Do not use fixing agents or cleaning substances containing halogens. Do not use coating and moulding components that completely seal the capacitor from the environment. Also, never use solvents containing: halogenated hydrocarbons, alkali, petroleum, trichloroethylene/-ethane, xylene, acetones, trichlorotrifluoroethane, tetrachloroethylene, methylenechloride, chloroform, acetates, ketones, esters, chlorides and bromides.

MOUNTING

Other devices, which are mounted near the capacitor, should not touch the capacitor. Additional heat coming from other components near the capacitor may reduce the lifetime of the capacitor. Do never bend or twist the capacitor after soldering to avoid stress on the leads. Radial capacitors are not protected against mechanical forces on the leads. Forces on the pins might damage the capacitor. No printed circuit board tracks are allowed between the lead pads of the capacitor. Screw Terminal capacitors should only be mounted in an upright position.

TRANSPORT

Avoid fumigation and spraying insecticides (especially with bromides) in the import or export procedures which can cause corrosion. This applies also to the finished devices.

MAINTENANCE

Periodical inspection should be carried out for the capacitor: visual inspection to check pressure relief open or leakage of electrolyte, electrical characteristics as leakage current, capacitance, and dissipation factor.

ELECTROLYTE AND SEPARATOR PAPER

Electrolyte and separator paper used in aluminum capacitors may be flammable. Also, electrolyte is electrically conductive. Therefore, in case electrolyte gets in contact with PC board it may cause corrosion of circuit pattern or cause short circuit between patterns, and may lead to smoke generation or ignition in worst case.

CAUTION DURING USE OF CAPACITORS

Do not touch the terminals of capacitors. Keep the capacitor free from conductive solution, such as acids, alkali and so on. Ensure that the operating environment of the equipment into which the capacitor has been built is within the specified conditions mentioned in the catalogue or specification sheets.

SAFETY VENT

The safety vent needs some free space to open properly. Allow for free headroom of at least 2mm for diameter $\leq 16mm$, more than 3mm for diameter 18-35mm, more than 5mm for case diameter 40mm and larger.

EMERGENCY ACTIONS

When the pressure relief vent is open and some gas blows out from the capacitor, please turn the main switch of the equipment off or pull out the plug from the power outlet immediately. During safety vent operation, extremely hot gas (>100°C) may blow out of the capacitors. Do not stand close to the capacitors. In case of eye contact, rinse the open eye(s) with clean water immediately. In case of ingestion, gargle with water immediately, do not swallow. Do not touch electrolyte but wash skin with soap and water in case of skin contact.

DEFINITION OF ELECTRICAL PARAMETERS

Separate documents as application notes, equivalent circuit diagrams and so on are available on request.

PACKAGING

Please refer to the data book for details. Further information is available on request.

DISPOSAL

Scrapped capacitors are classified as scrapped metal. For disposal they are handled as controllable industrial waste because of the nature of the contents (electrolyte). Most of the material is aluminum and cannot be completely burned.

Jianghai Europe Electronic Components GmbH

VERSION 10/2021

