

ALUMINUM ELECTROLYTIC CAPACITORS · RADIAL TYPE

# CD 287 GC SERIES

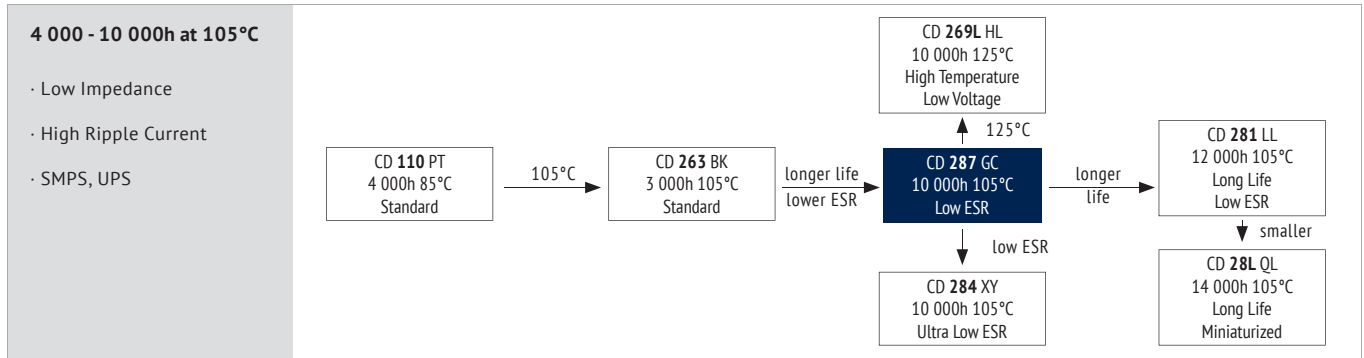

**ITEM CHARACTERISTICS**

Operating Temperature Range (°C)	-55 ~ +105
Voltage Range (V)	6,3 ~ 100
Capacitance Range (µF)	0,47 ~ 15 000
Capacitance Tolerance (20°C, 120Hz)	± 20%

**!** The usage at lower temperatures than indicated may be possible. Please contact the Jianghai Europe sales office for approval.

Leakage Current (µA) After 2 minutes at 20°C application of rated voltage, leakage current is not more than specified in table.

Stability at Low Temperature (Impedance Ratio at 120Hz)	Rated Voltage (V)	6,3 ~ 100
	Z <sub>-55°C</sub> / Z <sub>+20°C</sub>	3

**ITEM USEFUL LIFE LOAD LIFE ENDURANCE TEST SHELF LIFE**

Lifetime	Ø ≤ 6,3 : 4 000h Ø 8-10 : 6 000h Ø ≥ 12,5 : 10 000h	Ø ≥ 8 : > 250 000h	Ø ≤ 6,3 : 2 000h Ø 8-10 : 3 000h Ø ≥ 12,5 : 5 000h	Ø ≤ 6,3 : 3 000h Ø 8-10 : 5 000h Ø ≥ 12,5 : 7 000h	1 000h
Leakage Current	Not more than specified value		Not more than specified value	Not more than specified value	Not more than specified value
Capacitance Change	Within ± 30% of initial value		Within ± 20% of initial value	Within ± 20% of initial value	Within ± 20% of initial value
Dissipation Factor	Not more than 300% of specified value		Not more than 200% of specified value	Not more than 200% of specified value	Not more than 200% of specified value
Condition: Applied Voltage Applied Current Applied Temperature	U <sub>R</sub> I <sub>R</sub> 105°C	U <sub>R</sub> 1,4 x I <sub>R</sub> 40°C	U <sub>R</sub> I <sub>R</sub> 105°C	U <sub>R</sub> I <sub>R</sub> = 0 105°C IEC 60384	U <sub>R</sub> = 0 I <sub>R</sub> = 0 105°C  After test: U <sub>R</sub> to be applied for 30 min > 24h before measurement

**MULTIPLIER FOR RIPPLE CURRENT (FREQUENCY COEFFICIENT)**

Capacitance (µF)	Frequency			
	120Hz	1kHz	10kHz	100kHz
0,47 ~ 4,7	0,40	0,68	0,83	1,00
5,6 ~ 47	0,50	0,76	0,87	1,00
56 ~ 270	0,70	0,85	0,93	1,00
330 ~ 1 000	0,80	0,93	0,98	1,00
1 200 ~ 15 000	0,90	0,95	1,00	1,00

Multipliers for typical operating conditions.

**MULTIPLIER FOR LIFETIME (LIFETIME DIAGRAM)**

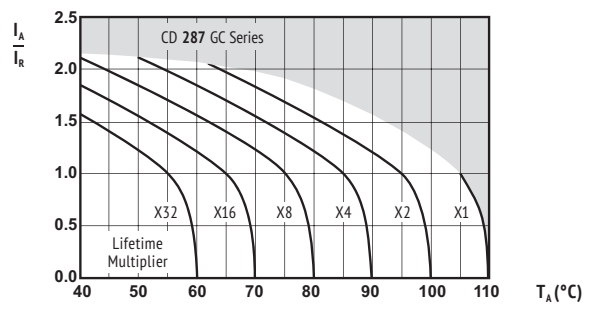

I<sub>A</sub> = actual ripple current at 100kHz,  
I<sub>R</sub> = rated ripple current at 100kHz, 105°C  
Multiplier of Useful Life as a function of ambient temperature & ripple current load

**ENVIRONMENTAL**

The products are RoHS, WEEE and RECh compliant. The detailed version please see separate "Environmental Certificates" document or [www.jianghai-europe.com](http://www.jianghai-europe.com)

**! SAFETY FACTOR**

This diagram includes a safety margin. In many cases the allowed current capability/lifetime may be increased. For details and approvals please contact the Jianghai Europe sales office.





U <sub>RDC</sub> (Surge Voltage) Code	C <sub>R</sub> Rated Capacitance	ESR <sub>max</sub> Equivalent Series Resistance	Z <sub>max</sub> Max Impedance		tanδ Dissipation Factor	I <sub>leak</sub> Leakage Current	I <sub>RAC</sub> Rated Ripple Current	Size øD x L	ORDER CODE
			20°C 120kHz	-10°C 100kHz					
(V)	(µF)	(Ω)	(Ω)	(Ω)		(µA)	(mArms)	(mm)	Details: Page 7
<b>6,3 (7,2) 0J</b>	100	2,92	0,650	1,30	0,22	13	175	5 x 11,5	ECR0JGC101M◇◇◇◇0511
	150	1,95	0,460	0,920	0,22	19	235	5 x 15	ECR0JGC151M◇◇◇◇0515
	220	1,33	0,300	0,600	0,22	28	290	6,3 x 11,5	ECR0JGC221M◇◇◇◇0611
	330	0,885	0,200	0,400	0,22	42	400	6,3 x 15	ECR0JGC331M◇◇◇◇0615
	470	0,621	0,170	0,340	0,22	60	488	8 x 11,5	ECR0JGC471M◇◇◇◇0811
	680	0,430	0,130	0,260	0,22	86	617	8 x 16	ECR0JGC681M◇◇◇◇0816
		0,430	0,120	0,240	0,22	86	613	10 x 12,5	ECR0JGC681M◇◇◇◇1012
	820	0,356	0,095	0,190	0,22	104	734	10 x 16	ECR0JGC821M◇◇◇◇1016
	1 000	0,292	0,095	0,190	0,22	126	800	8 x 20	ECR0JGC102M◇◇◇◇0820
	1 200	0,244	0,065	0,130	0,22	152	1010	10 x 20	ECR0JGC122M◇◇◇◇1020
		0,244	0,065	0,130	0,22	152	1010	12,5 x 15	ECR0JGC122M◇◇◇◇1215
	1 500	0,195	0,055	0,110	0,22	189	1190	10 x 25	ECR0JGC152M◇◇◇◇1025
	2 200	0,145	0,045	0,090	0,24	278	1440	10 x 30	ECR0JGC222M◇◇◇◇1030
		0,145	0,042	0,084	0,24	278	1400	12,5 x 20	ECR0JGC222M◇◇◇◇1220
	2 700	0,118	0,038	0,076	0,24	341	1690	12,5 x 25	ECR0JGC272M◇◇◇◇1225
		0,118	0,046	0,092	0,24	341	1310	16 x 15	ECR0JGC272M◇◇◇◇1615
	3 300	0,105	0,043	0,086	0,26	416	1460	18 x 15	ECR0JGC332M◇◇◇◇1815
	3 900	0,089	0,032	0,064	0,26	492	1950	12,5 x 30	ECR0JGC392M◇◇◇◇1230
	4 700	0,080	0,028	0,056	0,28	593	2220	12,5 x 35	ECR0JGC472M◇◇◇◇1235
		0,080	0,034	0,068	0,28	593	1660	16 x 20	ECR0JGC472M◇◇◇◇1620
5 600	0,072	0,026	0,052	0,30	706	2390	12,5 x 40	ECR0JGC562M◇◇◇◇1240	
	0,072	0,028	0,056	0,30	706	2070	16 x 25	ECR0JGC562M◇◇◇◇1625	
	0,072	0,030	0,060	0,30	706	1850	18 x 20	ECR0JGC562M◇◇◇◇1820	
6 800	0,063	0,025	0,050	0,32	857	2350	16 x 31,5	ECR0JGC682M◇◇◇◇1631	
	0,063	0,027	0,054	0,32	857	2120	18 x 25	ECR0JGC682M◇◇◇◇1825	
8 200	0,059	0,022	0,044	0,36	1034	2550	16 x 35,5	ECR0JGC822M◇◇◇◇1635	
10 000	0,054	0,023	0,046	0,40	1260	2410	18 x 31,5	ECR0JGC103M◇◇◇◇1831	
12 000	0,049	0,020	0,040	0,44	1512	2970	16 x 40	ECR0JGC123M◇◇◇◇1640	
	0,049	0,020	0,040	0,44	1512	2680	18 x 35,5	ECR0JGC123M◇◇◇◇1835	
15 000	0,045	0,019	0,038	0,50	1890	3010	18 x 40	ECR0JGC153M◇◇◇◇1840	
<b>10 (13) 1A</b>	82	3,08	0,650	1,30	0,19	17	175	5 x 11,5	ECR1AGC820M◇◇◇◇0511
	100	2,53	0,460	0,920	0,19	20	235	5 x 15	ECR1AGC101M◇◇◇◇0515
	180	1,41	0,300	0,600	0,19	36	290	6,3 x 11,5	ECR1AGC181M◇◇◇◇0611
	220	1,15	0,200	0,400	0,19	44	400	6,3 x 15	ECR1AGC221M◇◇◇◇0615
	330	0,764	0,170	0,340	0,19	66	488	8 x 11,5	ECR1AGC331M◇◇◇◇0811
	470	0,537	0,130	0,260	0,19	94	617	8 x 16	ECR1AGC471M◇◇◇◇0816
		0,537	0,120	0,240	0,19	94	613	10 x 12,5	ECR1AGC471M◇◇◇◇1012
	560	0,450	0,095	0,190	0,19	112	734	10 x 16	ECR1AGC561M◇◇◇◇1016
	680	0,371	0,095	0,190	0,19	136	800	8 x 20	ECR1AGC681M◇◇◇◇0820
	1 000	0,252	0,065	0,130	0,19	200	1010	10 x 20	ECR1AGC102M◇◇◇◇1020
		0,252	0,065	0,130	0,19	200	1010	12,5 x 15	ECR1AGC102M◇◇◇◇1215
	1 200	0,210	0,055	0,110	0,19	240	1190	10 x 25	ECR1AGC122M◇◇◇◇1025
	1 500	0,168	0,045	0,090	0,19	300	1440	10 x 30	ECR1AGC152M◇◇◇◇1030
	1 800	0,140	0,042	0,084	0,19	360	1400	12,5 x 20	ECR1AGC182M◇◇◇◇1220
		0,140	0,046	0,092	0,19	360	1310	16 x 15	ECR1AGC182M◇◇◇◇1615
	2 200	0,127	0,038	0,076	0,21	440	1690	12,5 x 25	ECR1AGC222M◇◇◇◇1225
		0,127	0,043	0,086	0,21	440	1460	18 x 15	ECR1AGC222M◇◇◇◇1815
	2 700	0,104	0,032	0,064	0,21	540	1950	12,5 x 30	ECR1AGC272M◇◇◇◇1230
	3 300	0,093	0,028	0,056	0,23	660	2220	12,5 x 35	ECR1AGC332M◇◇◇◇1235
		0,093	0,034	0,068	0,23	660	1660	16 x 20	ECR1AGC332M◇◇◇◇1620
3 900	0,079	0,026	0,052	0,23	780	2390	12,5 x 40	ECR1AGC392M◇◇◇◇1240	
	0,079	0,028	0,056	0,23	780	2070	16 x 25	ECR1AGC392M◇◇◇◇1625	
	0,079	0,030	0,060	0,23	780	1850	18 x 20	ECR1AGC392M◇◇◇◇1820	
4 700	0,071	0,027	0,054	0,25	940	2120	18 x 25	ECR1AGC472M◇◇◇◇1825	
5 600	0,064	0,025	0,050	0,27	1120	2350	16 x 31,5	ECR1AGC562M◇◇◇◇1631	
6 800	0,057	0,022	0,044	0,29	1360	2550	16 x 35,5	ECR1AGC682M◇◇◇◇1635	
	0,057	0,023	0,046	0,29	1360	2410	18 x 31,5	ECR1AGC682M◇◇◇◇1831	
8 200	0,054	0,020	0,040	0,33	1640	2970	16 x 40	ECR1AGC822M◇◇◇◇1640	
	0,054	0,020	0,040	0,33	1640	2680	18 x 35,5	ECR1AGC822M◇◇◇◇1835	
10 000	0,050	0,019	0,038	0,37	2000	3010	18 x 40	ECR1AGC103M◇◇◇◇1840	
<b>16 (20) 1C</b>	56	3,80	0,650	1,30	0,16	18	175	5 x 11,5	ECR1CGC560M◇◇◇◇0511
	82	2,59	0,460	0,920	0,16	27	235	5 x 15	ECR1CGC820M◇◇◇◇0515
	120	1,77	0,300	0,600	0,16	39	290	6,3 x 11,5	ECR1CGC121M◇◇◇◇0611
	180	1,18	0,200	0,400	0,16	58	400	6,3 x 15	ECR1CGC181M◇◇◇◇0615
	270	0,786	0,170	0,340	0,16	87	501	8 x 11,5	ECR1CGC271M◇◇◇◇0811





U <sub>RDC</sub> (Surge Voltage) Code	C <sub>R</sub> Rated Capacitance	ESR <sub>max</sub>	Z <sub>max</sub>	Z <sub>max</sub>	tanδ	I <sub>leak</sub> Leakage Current	I <sub>RAC</sub> Rated Ripple Current	Size øD x L	ORDER CODE
		Equivalent Series Resistance	Max Impedance	Max Impedance					
(V)	(µF)	20°C 120Hz (Ω)	20°C 100kHz (Ω)	-10°C 100kHz (Ω)	20°C 120Hz	(µA)	105°C 100kHz (mArms)	(mm)	Details: Page 7
<b>16</b> (20) 1C	330	0,644	0,130	0,260	0,16	106	575	8 x 16	ECR1CGC331M◇◇◇◇0816
		0,644	0,120	0,240	0,16	106	625	10 x 12,5	ECR1CGC331M◇◇◇◇1012
	390	0,545	0,095	0,190	0,16	125	795	10 x 16	ECR1CGC391M◇◇◇◇1016
		0,452	0,095	0,190	0,16	151	760	8 x 20	ECR1CGC471M◇◇◇◇0820
	680	0,313	0,065	0,130	0,16	218	1010	10 x 20	ECR1CGC681M◇◇◇◇1020
		0,313	0,065	0,130	0,16	218	1010	12,5 x 15	ECR1CGC681M◇◇◇◇1215
	820	0,259	0,055	0,110	0,16	263	1190	10 x 25	ECR1CGC821M◇◇◇◇1025
		1 200	0,177	0,045	0,090	0,16	384	1430	10 x 30
	1 500		0,177	0,042	0,084	0,16	384	1400	12,5 x 20
		1 500	0,142	0,038	0,076	0,16	480	1690	12,5 x 25
	2 200		0,142	0,046	0,092	0,16	480	1340	16 x 15
		2 200	0,142	0,043	0,086	0,16	480	1490	18 x 15
	2 700		0,109	0,032	0,064	0,18	704	1950	12,5 x 30
		2 700	0,109	0,034	0,068	0,18	704	1730	16 x 20
	2 700		0,089	0,028	0,056	0,18	864	2200	12,5 x 35
		2 700	0,089	0,028	0,056	0,18	864	2070	16 x 25
	3 300		0,089	0,030	0,060	0,18	864	1870	18 x 20
		3 900	0,081	0,026	0,052	0,20	1056	2390	12,5 x 40
	3 900		0,069	0,025	0,050	0,20	1248	2350	16 x 31,5
		3 900	0,069	0,027	0,054	0,20	1248	2160	18 x 25
4 700	0,063		0,022	0,044	0,22	1504	2550	16 x 35,5	ECR1CGC472M◇◇◇◇1635
	4 700	0,063	0,023	0,046	0,22	1504	2450	18 x 31,5	ECR1CGC472M◇◇◇◇1831
5 600		0,057	0,020	0,040	0,24	1792	2900	16 x 40	ECR1CGC562M◇◇◇◇1640
6 800	0,051	0,020	0,040	0,26	2176	2730	18 x 35,5	ECR1CGC682M◇◇◇◇1835	
8 200	0,049	0,019	0,038	0,30	2624	3060	18 x 40	ECR1CGC822M◇◇◇◇1840	
<b>25</b> (32) 1E	39	4,77	0,650	1,30	0,14	20	175	5 x 11,5	ECR1EGC390M◇◇◇◇0511
	56	3,32	0,460	0,920	0,14	28	235	5 x 15	ECR1EGC560M◇◇◇◇0515
	82	2,27	0,300	0,600	0,14	41	290	6,3 x 11,5	ECR1EGC820M◇◇◇◇0611
	120	1,55	0,200	0,400	0,14	60	400	6,3 x 15	ECR1EGC121M◇◇◇◇0615
	180	1,04	0,170	0,340	0,14	90	503	8 x 11,5	ECR1EGC181M◇◇◇◇0811
	220	0,845	0,130	0,260	0,14	110	575	8 x 16	ECR1EGC221M◇◇◇◇0816
		0,845	0,120	0,240	0,14	110	629	10 x 12,5	ECR1EGC221M◇◇◇◇1012
	270	0,688	0,095	0,190	0,14	135	795	10 x 16	ECR1EGC271M◇◇◇◇1016
	330	0,563	0,095	0,190	0,14	165	751	8 x 20	ECR1EGC331M◇◇◇◇0820
	470	0,396	0,065	0,130	0,14	235	1010	10 x 20	ECR1EGC471M◇◇◇◇1020
		0,396	0,065	0,130	0,14	235	1010	12,5 x 15	ECR1EGC471M◇◇◇◇1215
	560	0,332	0,055	0,110	0,14	280	1190	10 x 25	ECR1EGC561M◇◇◇◇1025
	820	0,227	0,045	0,090	0,14	410	1440	10 x 30	ECR1EGC821M◇◇◇◇1030
		0,227	0,042	0,084	0,14	410	1400	12,5 x 20	ECR1EGC821M◇◇◇◇1220
	820	0,227	0,046	0,092	0,14	410	1360	16 x 15	ECR1EGC821M◇◇◇◇1615
		1 000	0,186	0,038	0,076	0,14	500	1690	12,5 x 25
	1 200	0,155	0,043	0,086	0,14	600	1500	18 x 15	ECR1EGC122M◇◇◇◇1815
	1 500	0,124	0,032	0,064	0,14	750	1950	12,5 x 30	ECR1EGC152M◇◇◇◇1230
		0,124	0,034	0,068	0,14	750	1730	16 x 20	ECR1EGC152M◇◇◇◇1620
	1 800	0,104	0,028	0,056	0,14	900	2200	12,5 x 35	ECR1EGC182M◇◇◇◇1235
0,104		0,028	0,056	0,14	900	2070	16 x 25	ECR1EGC182M◇◇◇◇1625	
2 200	0,104	0,030	0,060	0,14	900	1890	18 x 20	ECR1EGC182M◇◇◇◇1820	
	2 200	0,097	0,026	0,052	0,16	1100	2390	12,5 x 40	ECR1EGC222M◇◇◇◇1240
2 700	0,079	0,025	0,050	0,16	1350	2350	16 x 31,5	ECR1EGC272M◇◇◇◇1631	
	0,079	0,027	0,054	0,16	1350	2180	18 x 25	ECR1EGC272M◇◇◇◇1825	
3 300	0,073	0,022	0,044	0,18	1650	2550	16 x 35,5	ECR1EGC332M◇◇◇◇1635	
	0,073	0,023	0,046	0,18	1650	2470	18 x 31,5	ECR1EGC332M◇◇◇◇1831	
3 900	0,062	0,020	0,040	0,18	1950	2900	16 x 40	ECR1EGC392M◇◇◇◇1640	
	0,062	0,020	0,040	0,18	1950	2740	18 x 35,5	ECR1EGC392M◇◇◇◇1835	
4 700	0,057	0,019	0,038	0,20	2350	3070	18 x 40	ECR1EGC472M◇◇◇◇1840	
<b>35</b> (44) 1V	27	5,90	0,650	1,30	0,12	19	175	5 x 11,5	ECR1VGC270M◇◇◇◇0511
	39	4,09	0,460	0,920	0,12	28	235	5 x 15	ECR1VGC390M◇◇◇◇0515
	56	2,85	0,300	0,600	0,12	40	290	6,3 x 11,5	ECR1VGC560M◇◇◇◇0611
	82	1,95	0,200	0,400	0,12	58	400	6,3 x 15	ECR1VGC820M◇◇◇◇0615
	120	1,33	0,170	0,340	0,12	84	501	8 x 11,5	ECR1VGC121M◇◇◇◇0811
	150	1,07	0,120	0,240	0,12	105	625	10 x 12,5	ECR1VGC151M◇◇◇◇1012
	180	0,885	0,130	0,260	0,12	126	575	8 x 16	ECR1VGC181M◇◇◇◇0816
		0,885	0,095	0,190	0,12	126	795	10 x 16	ECR1VGC181M◇◇◇◇1016
	220	0,724	0,095	0,190	0,12	154	760	8 x 20	ECR1VGC221M◇◇◇◇0820
	330	0,483	0,065	0,130	0,12	231	1010	10 x 20	ECR1VGC331M◇◇◇◇1020
		0,483	0,065	0,130	0,12	231	1010	12,5 x 15	ECR1VGC331M◇◇◇◇1215





U <sub>RDC</sub> (Surge Voltage) Code	C <sub>R</sub> Rated Capacitance	ESR <sub>max</sub> Equivalent Series Resistance		Z <sub>max</sub> Max Impedance		tanδ Dissipation Factor	I <sub>leak</sub> Leakage Current	I <sub>RAC</sub> Rated Ripple Current	Size øD x L	ORDER CODE
		20°C 120Hz	20°C 100kHz	20°C 100kHz	-10°C 100kHz					
		(Ω)	(Ω)	(Ω)	(Ω)					
(V)	(μF)	(Ω)	(Ω)	(Ω)	(Ω)	(μA)	(mArms)	(mm)	Details: Page 7	
<b>35</b> (44) 1V	390	0,409	0,055	0,110	0,12	273	1190	10 x 25	ECR1VGC391M◇◇△△1025	
	560	0,285	0,045	0,090	0,12	392	1450	10 x 30	ECR1VGC561M◇◇△△1030	
		0,285	0,042	0,084	0,12	392	1400	12,5 x 20	ECR1VGC561M◇◇△△1220	
		0,285	0,046	0,092	0,12	392	1360	16 x 15	ECR1VGC561M◇◇△△1615	
	680	0,235	0,038	0,076	0,12	476	1690	12,5 x 25	ECR1VGC681M◇◇△△1225	
		0,235	0,043	0,086	0,12	476	1520	18 x 15	ECR1VGC681M◇◇△△1815	
	1 000	0,160	0,032	0,064	0,12	700	1950	12,5 x 30	ECR1VGC102M◇◇△△1230	
		0,160	0,034	0,068	0,12	700	1730	16 x 20	ECR1VGC102M◇◇△△1620	
	1 200	0,133	0,028	0,056	0,12	840	2200	12,5 x 35	ECR1VGC122M◇◇△△1235	
		0,133	0,028	0,056	0,12	840	2070	16 x 25	ECR1VGC122M◇◇△△1625	
		0,133	0,030	0,060	0,12	840	1900	18 x 20	ECR1VGC122M◇◇△△1820	
	1 500	0,107	0,026	0,052	0,12	1050	2390	12,5 x 40	ECR1VGC152M◇◇△△1240	
	1 800	0,089	0,025	0,050	0,12	1260	2350	16 x 31,5	ECR1VGC182M◇◇△△1631	
		0,089	0,027	0,054	0,12	1260	2200	18 x 25	ECR1VGC182M◇◇△△1825	
	2 200	0,085	0,022	0,044	0,14	1540	2550	16 x 35,5	ECR1VGC222M◇◇△△1635	
		0,085	0,023	0,046	0,14	1540	2490	18 x 31,5	ECR1VGC222M◇◇△△1831	
	2 700	0,069	0,020	0,040	0,14	1890	2900	16 x 40	ECR1VGC272M◇◇△△1640	
		0,069	0,020	0,040	0,14	1890	2770	18 x 35,5	ECR1VGC272M◇◇△△1835	
3 300	0,065	0,019	0,038	0,16	2310	3110	18 x 40	ECR1VGC332M◇◇△△1840		
<b>50</b> (63) 1H	0,47	283	3,90	7,80	0,10	3	22	5 x 11,5	ECR1HGC47M◇◇△△0511	
	1,0	133	3,50	7,00	0,10	3	36	5 x 11,5	ECR1HGC010M◇◇△△0511	
	2,2	60,4	3,00	6,00	0,10	3	54	5 x 11,5	ECR1HGC2R2M◇◇△△0511	
	3,3	40,3	2,60	5,20	0,10	4	63	5 x 11,5	ECR1HGC3R3M◇◇△△0511	
	4,7	28,3	2,20	4,40	0,10	5	75	5 x 11,5	ECR1HGC4R7M◇◇△△0511	
	10	13,3	1,40	2,80	0,10	10	110	5 x 11,5	ECR1HGC100M◇◇△△0511	
	18	7,38	0,950	1,90	0,10	18	120	5 x 11,5	ECR1HGC180M◇◇△△0511	
	27	4,92	0,550	1,10	0,10	27	135	5 x 15	ECR1HGC270M◇◇△△0515	
	39	3,41	0,360	0,720	0,10	39	148	6,3 x 11,5	ECR1HGC390M◇◇△△0611	
	56	2,37	0,280	0,560	0,10	56	153	6,3 x 15	ECR1HGC560M◇◇△△0615	
	68	1,96	0,200	0,400	0,10	68	360	8 x 11,5	ECR1HGC680M◇◇△△0811	
	82	1,62	0,180	0,360	0,10	82	460	8 x 16	ECR1HGC820M◇◇△△0816	
		1,62	0,180	0,360	0,10	82	443	10 x 12,5	ECR1HGC820M◇◇△△1012	
	100	1,33	0,150	0,300	0,10	100	553	10 x 16	ECR1HGC101M◇◇△△1016	
	120	1,11	0,130	0,260	0,10	120	670	8 x 20	ECR1HGC121M◇◇△△0820	
	180	0,737	0,095	0,190	0,10	180	676	10 x 20	ECR1HGC181M◇◇△△1020	
		0,737	0,105	0,210	0,10	180	745	12,5 x 15	ECR1HGC181M◇◇△△1215	
	220	0,603	0,080	0,160	0,10	220	876	10 x 25	ECR1HGC221M◇◇△△1025	
	330	0,402	0,065	0,130	0,10	330	1010	10 x 30	ECR1HGC331M◇◇△△1030	
		0,402	0,070	0,140	0,10	330	979	12,5 x 20	ECR1HGC331M◇◇△△1220	
		0,402	0,075	0,150	0,10	330	982	16 x 15	ECR1HGC331M◇◇△△1615	
	470	0,283	0,054	0,108	0,10	470	1180	12,5 x 25	ECR1HGC471M◇◇△△1225	
		0,283	0,058	0,116	0,10	470	1180	18 x 15	ECR1HGC471M◇◇△△1815	
	560	0,237	0,050	0,100	0,10	560	1310	12,5 x 30	ECR1HGC561M◇◇△△1230	
	680	0,196	0,046	0,092	0,10	680	1470	12,5 x 35	ECR1HGC681M◇◇△△1235	
		0,196	0,050	0,100	0,10	680	1210	16 x 20	ECR1HGC681M◇◇△△1620	
	820	0,162	0,044	0,088	0,10	820	1590	12,5 x 40	ECR1HGC821M◇◇△△1240	
		0,162	0,048	0,096	0,10	820	1490	16 x 25	ECR1HGC821M◇◇△△1625	
0,162		0,046	0,092	0,10	820	1450	18 x 20	ECR1HGC821M◇◇△△1820		
1 000	0,133	0,040	0,080	0,10	1000	1890	16 x 31,5	ECR1HGC102M◇◇△△1631		
	0,133	0,040	0,080	0,10	1000	1720	18 x 25	ECR1HGC102M◇◇△△1825		
1 200	0,111	0,032	0,064	0,10	1200	2140	16 x 35,5	ECR1HGC122M◇◇△△1635		
1 500	0,089	0,026	0,052	0,10	1500	2410	16 x 40	ECR1HGC152M◇◇△△1640		
	0,089	0,026	0,052	0,10	1500	1970	18 x 31,5	ECR1HGC152M◇◇△△1831		
1 800	0,074	0,025	0,050	0,10	1800	2310	18 x 35,5	ECR1HGC182M◇◇△△1835		
2 200	0,073	0,024	0,048	0,12	2200	2530	18 x 40	ECR1HGC222M◇◇△△1840		
<b>63</b> (79) 1J	12	9,96	1,20	3,60	0,09	16	120	5 x 11,5	ECR1JGC120M◇◇△△0511	
	18	6,64	0,850	2,60	0,09	23	135	5 x 15	ECR1JGC180M◇◇△△0515	
	27	4,43	0,550	1,70	0,09	34	148	6,3 x 11,5	ECR1JGC270M◇◇△△0611	
	39	3,07	0,380	1,10	0,09	50	153	6,3 x 15	ECR1JGC390M◇◇△△0615	
	47	2,55	0,320	0,960	0,09	60	360	8 x 11,5	ECR1JGC470M◇◇△△0811	
	56	2,14	0,230	0,690	0,09	71	448	10 x 12,5	ECR1JGC560M◇◇△△1012	
	68	1,76	0,240	0,720	0,09	86	469	8 x 16	ECR1JGC680M◇◇△△0816	
		1,76	0,170	0,510	0,09	86	553	10 x 16	ECR1JGC680M◇◇△△1016	
	82	1,46	0,170	0,510	0,09	104	682	8 x 20	ECR1JGC820M◇◇△△0820	
	120	0,995	0,120	0,360	0,09	152	676	10 x 20	ECR1JGC121M◇◇△△1020	

>>





U <sub>RDC</sub> (Surge Voltage) Code	C <sub>R</sub> Rated Capacitance	ESR <sub>max</sub> Equivalent Series Resistance		Z <sub>max</sub> Max Impedance		tanδ Dissipation Factor	I <sub>leak</sub> Leakage Current	I <sub>RAC</sub> Rated Ripple Current	Size øD x L	ORDER CODE
		20°C 120Hz	20°C 100kHz	20°C 100kHz	-10°C 100kHz					
(V)	(µF)	(Ω)	(Ω)	(Ω)	(Ω)		(µA)	(mArms)	(mm)	Details: Page 7
<b>63</b> (79) 1J	150	0,796	0,100	0,300	0,09	189	876	10 x 25	ECR1JGC151M◇◇△△1025	
		0,796	0,110	0,350	0,09	189	745	12,5 x 15	ECR1JGC151M◇◇△△1215	
	180	0,664	0,085	0,260	0,09	227	1020	10 x 30	ECR1JGC181M◇◇△△1030	
		0,543	0,075	0,230	0,09	278	979	12,5 x 20	ECR1JGC221M◇◇△△1220	
	220	0,543	0,080	0,240	0,09	278	982	16 x 15	ECR1JGC221M◇◇△△1615	
		0,443	0,065	0,200	0,09	341	1180	12,5 x 25	ECR1JGC271M◇◇△△1225	
	330	0,362	0,065	0,200	0,09	416	1200	18 x 15	ECR1JGC331M◇◇△△1815	
		0,307	0,055	0,170	0,09	492	1310	12,5 x 30	ECR1JGC391M◇◇△△1230	
	390	0,307	0,057	0,170	0,09	492	1210	16 x 20	ECR1JGC391M◇◇△△1620	
		0,254	0,048	0,140	0,09	593	1470	12,5 x 35	ECR1JGC471M◇◇△△1235	
	470	0,254	0,052	0,160	0,09	593	1490	16 x 25	ECR1JGC471M◇◇△△1625	
		0,254	0,058	0,170	0,09	593	1460	18 x 20	ECR1JGC471M◇◇△△1820	
	560	0,214	0,042	0,130	0,09	706	1590	12,5 x 40	ECR1JGC561M◇◇△△1240	
		0,176	0,042	0,130	0,09	857	1890	16 x 31,5	ECR1JGC681M◇◇△△1631	
	680	0,176	0,050	0,150	0,09	857	1740	18 x 25	ECR1JGC681M◇◇△△1825	
		0,146	0,036	0,110	0,09	1034	2140	16 x 35,5	ECR1JGC821M◇◇△△1635	
	820	0,146	0,042	0,130	0,09	1034	1990	18 x 31,5	ECR1JGC821M◇◇△△1831	
		0,120	0,032	0,096	0,09	1260	2410	16 x 40	ECR1JGC102M◇◇△△1640	
1 000	0,120	0,035	0,110	0,09	1260	2340	18 x 35,5	ECR1JGC102M◇◇△△1835		
	1 200	0,100	0,032	0,096	0,09	1512	2560	18 x 40	ECR1JGC122M◇◇△△1840	
<b>100</b> (125) 2A	5,6	19,0	1,90	7,60	0,08	12	57	5 x 11,5	ECR2AGC5R6M◇◇△△0511	
	8,2	13,0	1,30	5,20	0,08	17	74	5 x 15	ECR2AGC8R2M◇◇△△0515	
	12	8,85	1,10	4,40	0,08	24	78	6,3 x 11,5	ECR2AGC120M◇◇△△0611	
	18	5,90	0,620	2,50	0,08	36	85	6,3 x 15	ECR2AGC180M◇◇△△0615	
	22	4,83	0,530	2,10	0,08	44	275	8 x 11,5	ECR2AGC220M◇◇△△0811	
	27	3,94	0,470	1,90	0,08	54	319	10 x 12,5	ECR2AGC270M◇◇△△1012	
		3,22	0,350	1,40	0,08	66	360	8 x 16	ECR2AGC330M◇◇△△0816	
	33	3,22	0,320	1,30	0,08	66	424	10 x 16	ECR2AGC330M◇◇△△1016	
		2,73	0,270	1,10	0,08	78	490	8 x 20	ECR2AGC390M◇◇△△0820	
	56	1,90	0,250	1,00	0,08	112	499	10 x 20	ECR2AGC560M◇◇△△1020	
	68	1,57	0,180	0,720	0,08	136	634	10 x 25	ECR2AGC680M◇◇△△1025	
		1,57	0,200	0,800	0,08	136	613	12,5 x 15	ECR2AGC680M◇◇△△1215	
	100	1,07	0,150	0,600	0,08	200	739	10 x 30	ECR2AGC101M◇◇△△1030	
		1,07	0,130	0,520	0,08	200	805	12,5 x 20	ECR2AGC101M◇◇△△1220	
	120	0,885	0,110	0,440	0,08	240	857	12,5 x 25	ECR2AGC121M◇◇△△1225	
		0,885	0,130	0,500	0,08	240	706	16 x 15	ECR2AGC121M◇◇△△1615	
	150	0,708	0,120	0,480	0,08	300	871	18 x 15	ECR2AGC151M◇◇△△1815	
	180	0,590	0,090	0,360	0,08	360	1120	12,5 x 30	ECR2AGC181M◇◇△△1230	
		0,590	0,110	0,440	0,08	360	916	16 x 20	ECR2AGC181M◇◇△△1620	
	220	0,483	0,075	0,300	0,08	440	1240	12,5 x 35	ECR2AGC221M◇◇△△1235	
		0,483	0,081	0,320	0,08	440	1290	16 x 25	ECR2AGC221M◇◇△△1625	
	270	0,393	0,060	0,240	0,08	540	1330	12,5 x 40	ECR2AGC271M◇◇△△1240	
		0,393	0,085	0,340	0,08	540	1170	18 x 20	ECR2AGC271M◇◇△△1820	
	330	0,322	0,059	0,230	0,08	660	1630	16 x 31,5	ECR2AGC331M◇◇△△1631	
		0,322	0,071	0,280	0,08	660	1500	18 x 25	ECR2AGC331M◇◇△△1825	
	390	0,273	0,052	0,210	0,08	780	1750	16 x 35,5	ECR2AGC391M◇◇△△1635	
		0,273	0,058	0,230	0,08	780	1630	18 x 31,5	ECR2AGC391M◇◇△△1831	
	470	0,226	0,045	0,180	0,08	940	1920	16 x 40	ECR2AGC471M◇◇△△1640	
560	0,190	0,054	0,220	0,08	1120	1920	18 x 35,5	ECR2AGC561M◇◇△△1835		
680	0,157	0,041	0,160	0,08	1360	2100	18 x 40	ECR2AGC681M◇◇△△1840		

**IMPEDANCE RATIO**

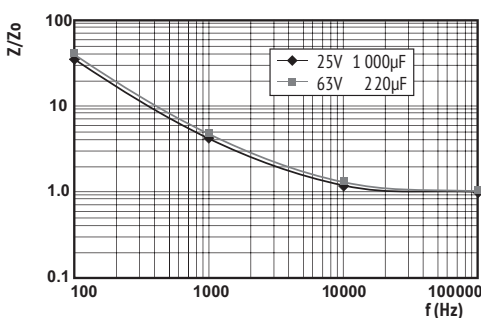

Z = actual impedance of each frequency at 20°C,  
Z<sub>0</sub> = Impedance at 100kHz, 20°C  
Impedance Ratio as a function of frequency

**CAPACITANCE RATIO**

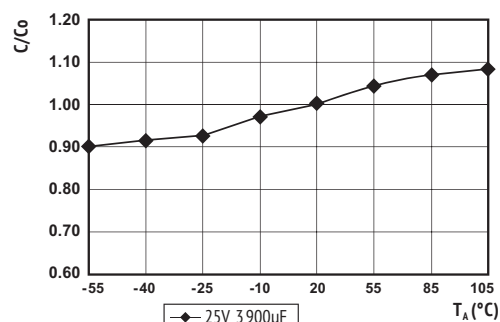

C = actual capacitance of each temperature at 100Hz,  
C<sub>0</sub> = Capacitance at 20°C, 100Hz  
Capacitance Ratio as a function of temperature (typical curve)





**ORDER CODE FOR RADIAL CAPACITORS**

EC	R	2G	QX	221	M	LL	50	1012	-	-	JExxxxx								
Techno-logy	Terminal Type	Rated Voltage Code	Series Code	Capacitance Code	Capacitance Tolerance	Terminal Style	Terminal / Pitch	Dimension (mm)	Material Code	Rubber Type	for Specials only								
EC Electrolytic Capacitor	Radial R	6,3V	0J	CD 110	PT	0,1	0R1	±20%	M	Taped	FF	2,0mm	20	4x7	0407	Standard	-	Standard	-
		10V	1A	CD 11GL	GL	0,47	R47	±10%	K	Long Lead	LL	2,5mm	25	5x11,5	0511	PVC	V	Flat Rubber	F
		16V	1C	CD 261	LK	1,0	010	+30 / -10%	Q	Cut 5,0mm	CB	3,5mm	35	10x20	1020	PET	E	Stand-Off	S
		20V	1D	CD 261L	DE	2,2	2R2	+20 / -0%	R	Cut 4,5mm	CC	5,0mm	50	12,5x25	1225				
		25V	1E	CD 261X	QX	100	101	±15%	L	Cut 4,0mm	CD	7,5mm	75						
		35V	1V	CD 263	BK	1000	102	+20 / -10%	V	Cut 3,5mm	CE	10,0mm	10						
		40V	1G	CD 269	PH	10 000	103	■ = preferred		Cut 3,0mm	CF	12,5mm	12						
		50V	1H	CD 269L	HL														
		63V	1J	CD 281	LL														
		80V	1K	CD 281L	LH														
		100V	2A	CD 282L	YL														
		125V	2B	CD 282X	EQ														
		160V	2C	CD 284	XY														
		180V	2K	CD 284L	LY														
		200V	2D	CD 285	HY														
		250V	2E	CD 287	GC														
		350V	2V	CD 28L	QL														
		385V	2J																
		400V	2G																
		415V	2P																
		420V	2X																
		450V	2W																
		500V	2H																
		550V	2Y																
575V	2Z																		
600V	2S																		
630V	J2																		

On request:  
Alternative lead forms  
(keyed polarity, 90° bended, others)

Packaging:  
Taped: ammopack  
Long lead & cut: bulk





## DIMENSIONS FOR LOOSE, LONG-LEAD TYPE (BULK)

· ORDER CODE: LL

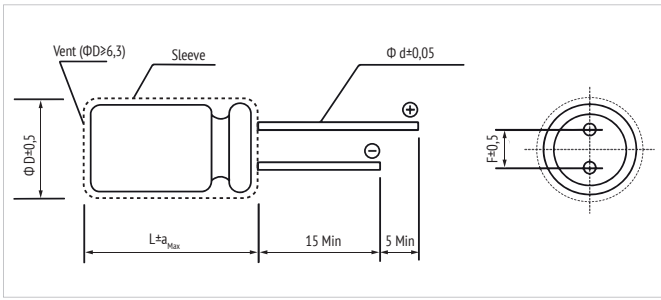

L	L ≤ 7					L ≥ 11									
	3	4	5	6,3	8	5	6,3	8	10	12,5	16	18	20	22	25
Ø D	3	4	5	6,3	8	5	6,3	8	10	12,5	16	18	20	22	25
F	1,0	1,5	2,0	2,5	3,5	2,0	2,5	3,5	5,0	7,5	10,0	12,5			
Ø d	0,4	0,45		0,5		0,6		0,8		1,0					
a <sub>Max</sub>	1,0		2,0				2,5								

For diameter 20 pitch 7,5 or 10.

in mm

## DIMENSIONS FOR LOOSE, SHORT CUT LEADS (BULK)

· ORDER CODE: CC (CB, CD, CE, CF)

### STRAIGHT LEAD

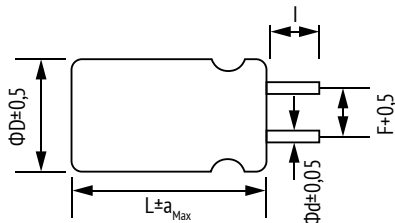

### BENDED LEAD

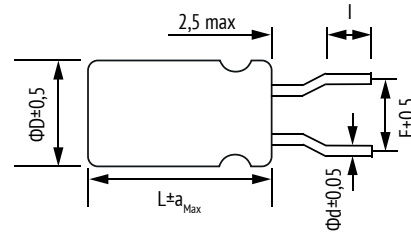

Code	CB	CC	CD	CE	CF
I	5,0 ± 0,5	4,5 ± 0,5	4,0 ± 0,5	3,5 ± 0,5	3,0 ± 0,5

■ = preferred

in mm

## EXAMPLE OF ALTERNATIVE BENDINGS

· ORDER CODE: WS

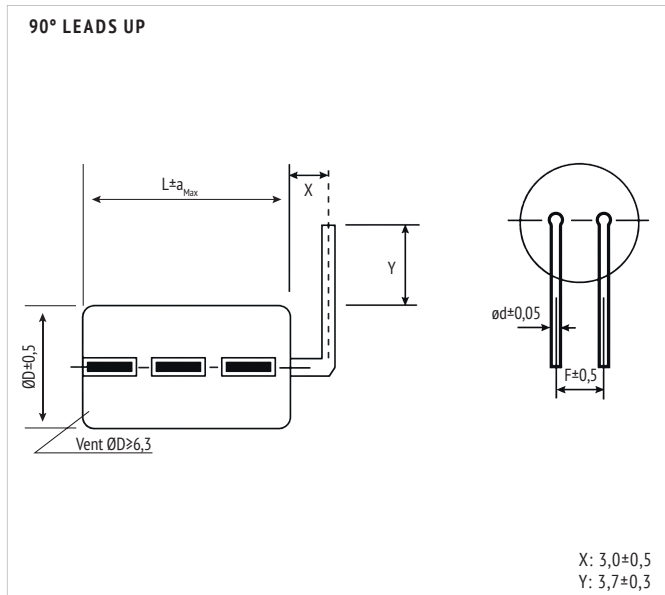

· ORDER CODE: WX

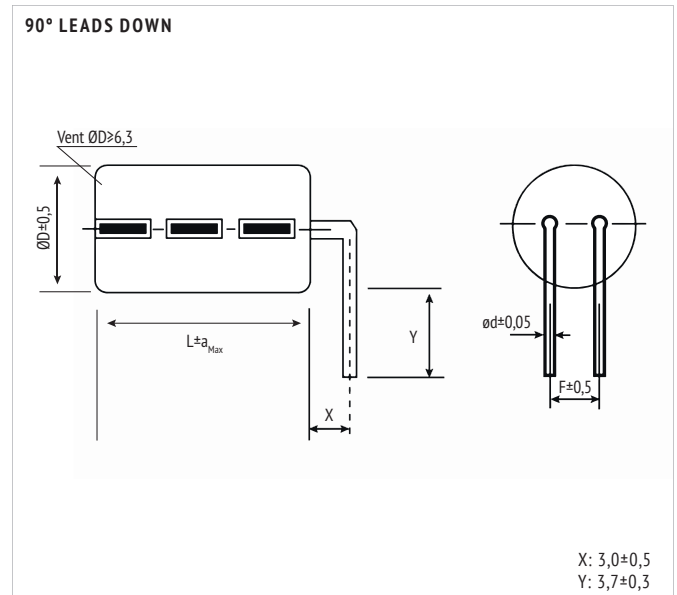





## DIMENSIONS FOR AMMOPACK TAPING FOR ELECTROLYTIC CAPACITORS

· ORDER CODE: FF (FD)

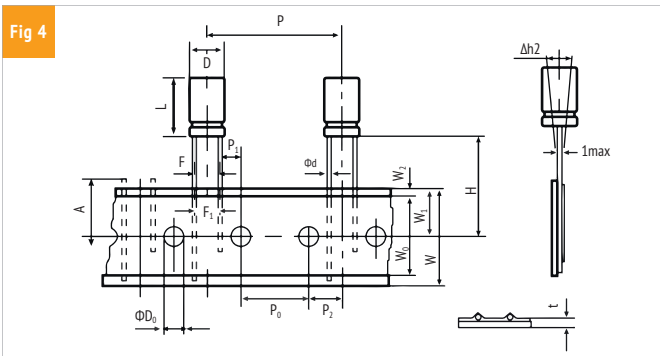
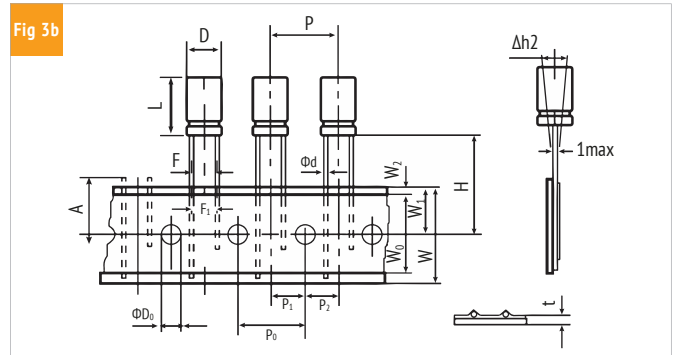
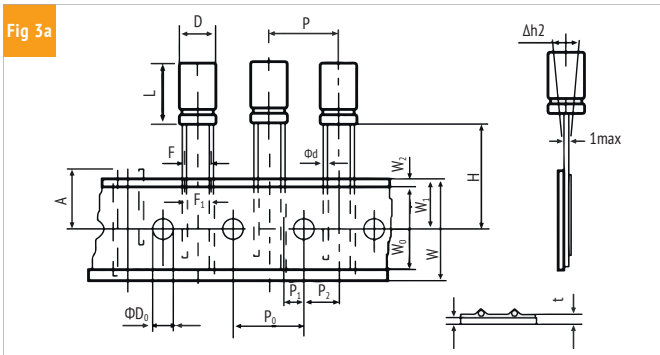
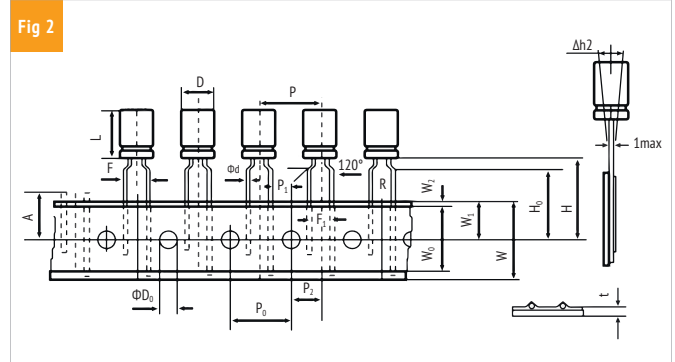
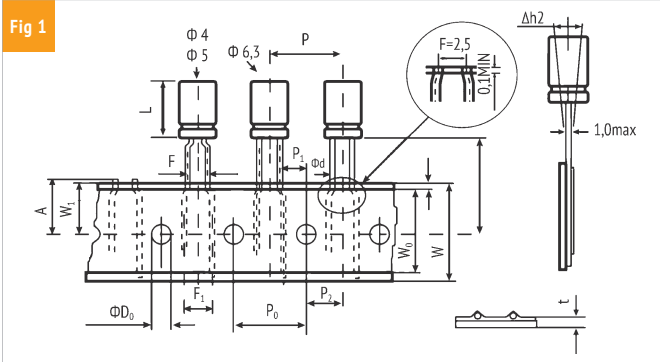

OTHER TAPING STYLES AVAILABLE ON REQUEST.

ITEM	D	L	Ød	P	P <sub>0</sub>	P <sub>1</sub>	P <sub>2</sub>	F	F <sub>1</sub>	W	W <sub>0</sub>	W <sub>1</sub>	W <sub>2</sub>	H	H <sub>0</sub>	A	ØD <sub>0</sub>	Δh <sub>2</sub>	t	Fig.	Taping Code
ToL.	± 0,5	± 2,0	± 0,05	± 1,0	± 0,2	± 0,5	± 1,0	+0,8 -0,2	± 1,0	± 0,5	min	± 0,5	max	+0,75 -0,5	± 0,5	max	± 0,5	max	± 0,2		
Nominal	4	7	0,45	12,7	12,7	5,1	6,35	2,5	3,5	18,0	10,0	9,0	1,5	18,5	-	11,0	4,0	1,0	0,7	1	FF
						3,85		5	5					17,5	16,0					2	FF
	5	7	0,45	12,7	12,7	5,1	6,35	2,5	3,5	18,0	10,0	9,0	1,5	18,5	-	11,0	4,0	1,0	0,7	1	FF
						3,85		5	5					17,5	16,0					2	FF
	5	11,5-15	0,5	12,7	12,7	5,1	6,35	2,5	3,5	18,0	10,0	9,0	1,5	18,5	-	11,0	4,0	1,0	0,7	1	FF
						3,85		5	5					16,0	16,0					2	FF
	6,3	7	0,45	12,7	12,7	5,1	6,35	2,5	3,5	18,0	10,0	9,0	1,5	18,5	-	11,0	4,0	1,0	0,7	1	FF
						3,85		5	5					17,5	16,0					2	FF
	6,3	11,5-15	0,5	12,7	12,7	5,1	6,35	2,5	3,5	18,0	10,0	9,0	1,5	18,5	-	11,0	4,0	1,0	0,7	1	FF
						3,85		5	5					16,0	16,0					2	FF
	8	11,5-20	0,6	12,7	12,7	4,6	6,35	3,5	3,5	18,0	10,0	9,0	1,5	18,5	-	11,0	4,0	1,0	0,7	3a	FF
						3,85		5	5					20,0	16,0					2	FF
10	12,5-36	0,6	12,7	12,7	3,85	6,35	5	5	18,0	10,0	9,0	1,5	18,5	-	11,0	4,0	1,0	0,7	3b	FF	
12,5	15-36	0,6	15	15	5,0	7,5	5	5	18,0	12,0	9,0	1,5	18,5	-	11,0	4,0	1,0	0,7	3b	FF	
			25,4	12,7	3,85	6,35													4	FD	
16	15-31,5	0,8	30	15	3,75	7,5	7,5	7,5	18,0	12,0	9,0	1,5	18,5	-	11,0	4,0	1,0	0,7	4	FD	
18	15-25,5	0,8	30	15	3,75	7,5	7,5	7,5	18,0	12,0	9,0	1,5	18,5	-	11,0	4,0	1,0	0,7	4	FD	

Other taping styles available on request

in mm





**RADIAL  
6,3V  
~  
100V**

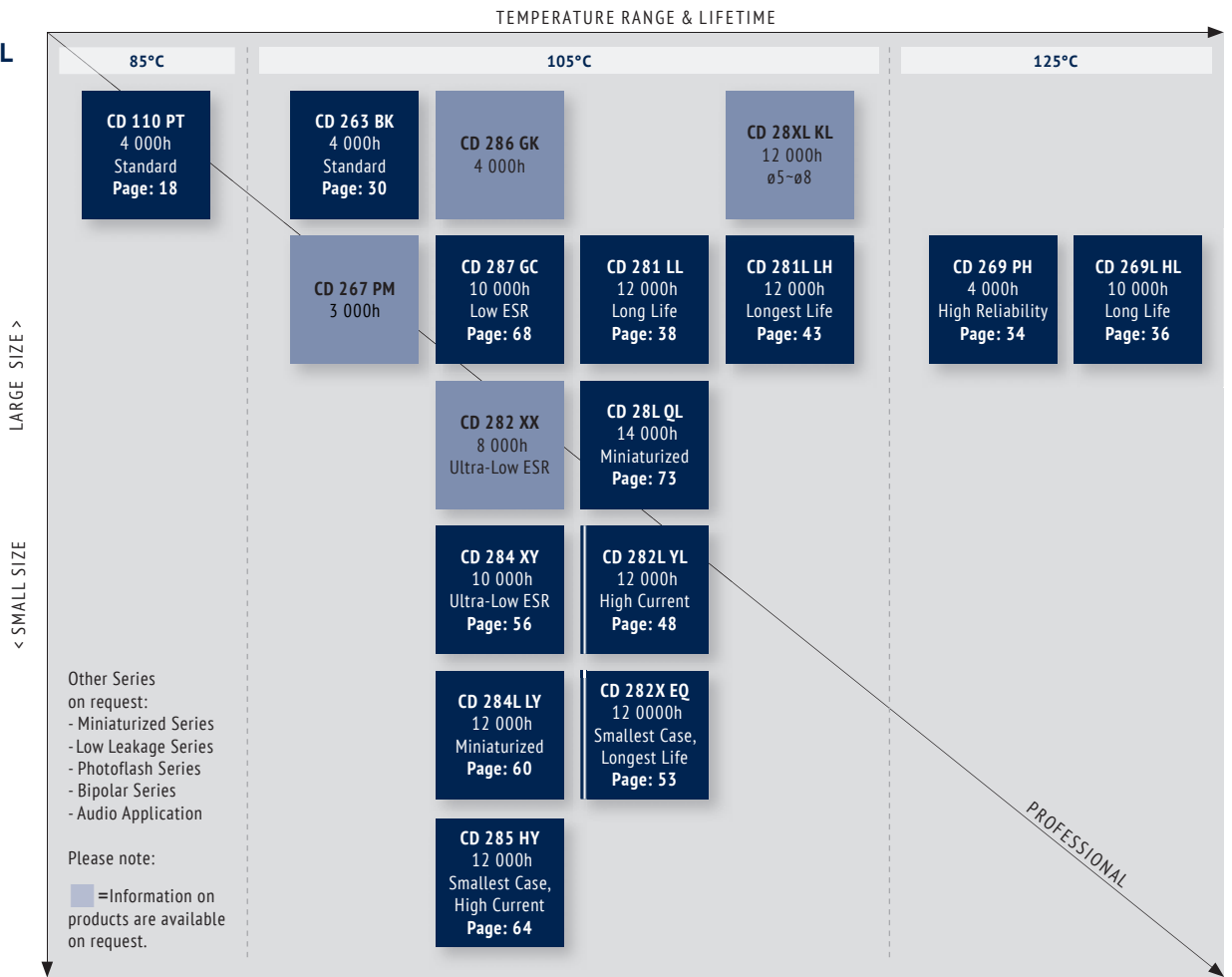

**RADIAL  
160V  
~  
550V**

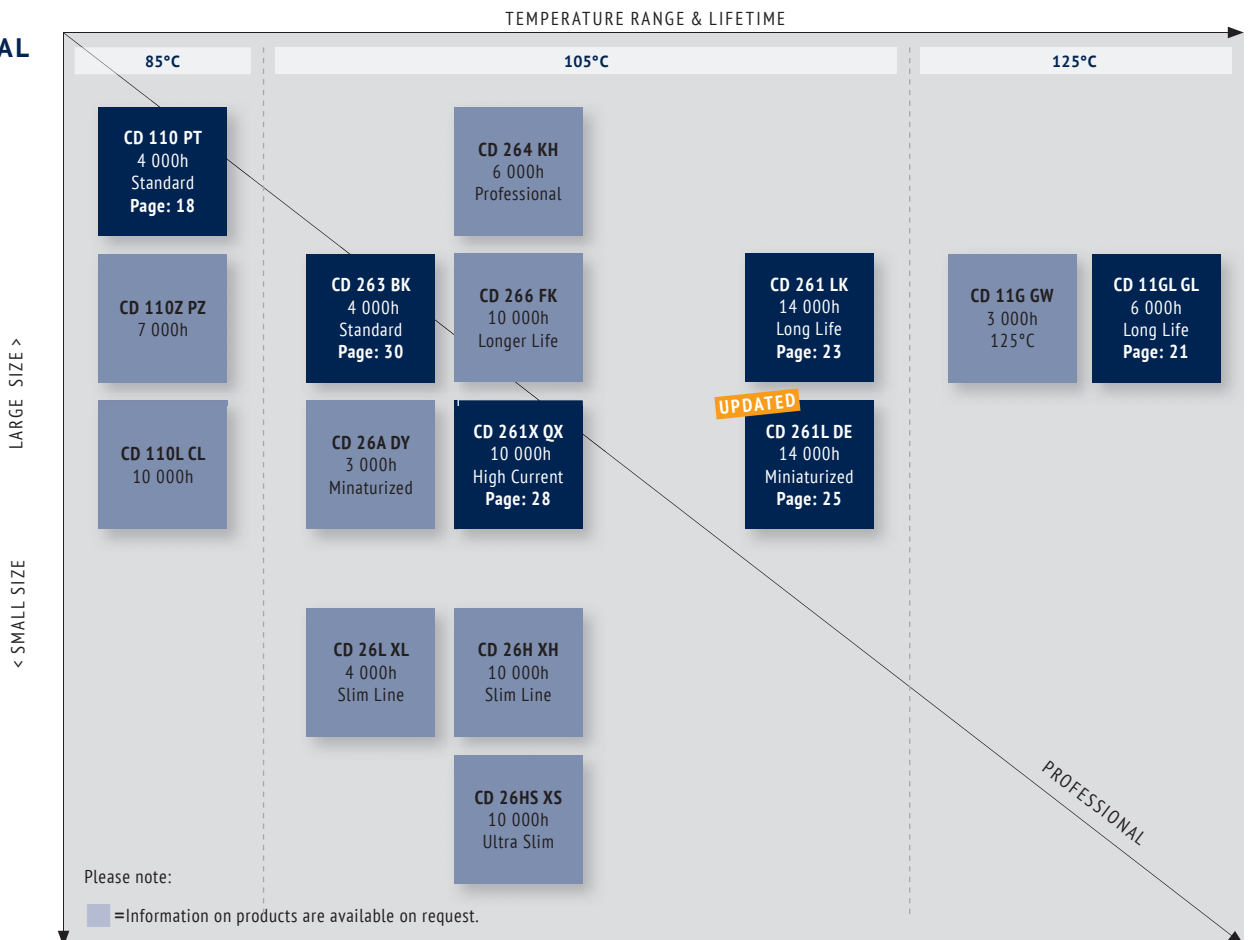



## LIFETIME ESTIMATION OF ALUMINUM ELECTROLYTIC CAPACITORS FROM JIANGHAI

To estimate the Lifetime of a non-solid Aluminum Electrolytic Capacitor from Jianghai, the following formulas can be utilized. The Lifetime depends mainly on the ambient temperature, the ripple current and, within certain limits, the operating voltage applied. Other parameters may also affect the Lifetime. Moreover,  $L_0$  can be interpreted in many different ways, which has a fundamental influence on the numerical result. Jianghai offers a high transparency by publishing the different typical definitions of Lifetimes in each datasheet. Lifetime estimations are approximations by nature. Please let JIANGHAI EUROPE confirm any result before using it. The formulas given here do not constitute part of a contract nor of a specification. The formulas do not cover additional aging effects of certain electrolytic systems or other chemical effects. Also the dimensions of the components may have an effect. Forced cooling or other additional cooling-methods have a strong impact on the Lifetime and are not covered by the formulas as defined. For the estimation and interpretation of Lifetime, a close collaboration with JIANGHAI EUROPE is strongly advised.

### STRUCTURAL FORMULA

$$L = L_0 \cdot K_T \cdot K_R \cdot K_V$$

WHERE:

- L Total Lifetime
- $L_0$  Lifetime under Nominal Load at Upper Category Temperature (see catalogue)
- $K_T$  Temperature Factor
- $K_R$  Ripple Current Factor
- $K_V$  Voltage Factor

### $K_T$ TEMPERATURE FACTOR

Aluminum Electrolytic Capacitors follow roughly the 10 K rule of Arrhenius. It is possible to estimate the Lifetime by rule of thumb: When the operational temperature is reduced by 10 K, the Lifetime will double. The formula for  $K_T$  in detail is:

$$K_T = 2^{\frac{T_0 - T_A}{10K}}$$

WHERE:

- $T_0$  Rated Temperature
- $T_A$  Ambient Temperature

### $K_R$ RIPPLE CURRENT FACTOR

To estimate the influence of ripple current on lifetime, Jianghai uses a safety factor  $K_i$ . Under certain conditions this value can be set to  $K_i=2$ , which is prolonging the lifetime. Please contact Jianghai Europe for details and approval.

$$K_R = K_i^A \frac{\Delta T_0}{10K}$$

WITH:

$$A = 1 - \left( \frac{I_A}{I_R} \right)^2$$

WHERE:

- $I_A$  Actual Rated Ripple Current
- $I_R$  Ripple Current at Upper Category Temperature (databook value)
- $\Delta T_0$  Core Temperature Rise of the capacitor (typically 3,5 ~ 5 K for  $T_0 = 105^\circ\text{C}$  and 3,5 ~ 10K for  $T_0 = 85^\circ\text{C}$ , see databook value)
- $K_i$  Basis, typically defined as
 

$T_0 = 105^\circ\text{C}$	$I_A > I_R$ :	$K_i=4$
	$I_A \leq I_R$ :	$K_i=2$
$T_0 = 85^\circ\text{C}$		$K_i=2$



*Remark: Safety Factor  $K_i$  may be set as  $K_i=2$  under certain defined conditions. Please contact Jianghai Europe for approval.*

### $K_V$ VOLTAGE FACTOR

For Radial Electrolytic Capacitors, this part of the formula has no impact ( $K_V = 1$ ). But for some bigger capacitors like Snap-In and Screw-Terminal types with rated voltages above 160V, the operating voltage will affect their Lifetime. It is expressed as follows:

FOR:

$$0,6 \leq \frac{U_A}{U_R} \leq 1$$

$$K_V = \left( \frac{U_A}{U_R} \right)^{-2,5}$$

WHERE:

- $U_A$  Actual Operating Voltage
- $U_R$  Rated Voltage





FOR:

$$0 < \frac{U_A}{U_R} < 0,6$$

$$K_V = 3,59$$

FOR:

$$\frac{U_A}{U_R} > 1 \text{ not allowed}$$

$$K_V = 1$$

FOR: Radial Capacitors or  $U_R \leq 160V$

$$K_V = 1$$

**FREQUENCY CORRECTION FACTORS:**

If the actual Ripple Currents are not given at the same frequency like  $I_{\sigma}$ , correction factors need to be applied.

$$I_A = \sqrt{\left(\frac{I_{f1}}{F_{f1}}\right)^2 + \left(\frac{I_{f2}}{F_{f2}}\right)^2 + \dots + \left(\frac{I_{fn}}{F_{fn}}\right)^2}$$

**JIANGHAI ELECTROLYTIC CAPACITOR LIFETIME**

**ESTIMATION FORMULA (incl. Safety Factors):**

$$L = L_0 \cdot 2^{\frac{T_0 - T_A}{10K}} \cdot K_i \left[ 1 - \left(\frac{I_A}{I_R}\right)^2 \right]^{\frac{\Delta T_0}{10K}} \cdot \underbrace{\left(\frac{U_A}{U_R}\right)^{-n}}_{K_V}$$

WITH TYPICAL VALUES:

$$T_0 = 105^\circ C \quad I_A > I_R : K_i = 4$$

$$I_A \leq I_R : K_i = 2$$

$$T_0 = 85^\circ C \quad K_i = 2$$

$\Delta T_0 =$  depending on the series: 3,5~10K,  
see databook value

$$0,6 \leq \frac{U_A}{U_R} \leq 1 \rightarrow n = 2,5$$

$$0 < \frac{U_A}{U_R} < 0,6 \rightarrow K_V = \left(\frac{U_A}{U_R}\right)^{-n} = 3,59$$

For  $U_R \leq 160V$ , Radial and

$$\frac{U_A}{U_R} > 1 \rightarrow K_V = 1$$

**HANDLING PRECAUTIONS FOR ALUMINUM ELECTROLYTIC CAPACITORS FROM JIANGHAI**

**WARNING**

JIANGHAI is not liable for any extent of possible injuries or damages to persons or things, of any kind, caused by the improper application of and/or operating conditions harmful to electrolytic capacitors. Misapplications which may cause failures include, but are not limited to: ripple current or peak current or voltage above specification, operating voltage above surge voltage specified, temperature exposure outside the specified operating temperature range. Examples of harmful operating conditions comprise, but are not limited to: unusual storage or transport temperatures, excessive and/or rapid changes of ambient temperature or humidity, heavy mechanical shock or vibration, corrosive and abrasive particles in the ambient (cooling) air, conducting dust in the ambient (cooling) air, oil or water vapor or corrosive substances, explosive gas or dust, operation under extremely high or low ambient pressure conditions (below or above sea level), superimposed radio frequency voltages, radioactivity. In case of doubt about the impact of operating conditions on capacitor performance, please contact JIANGHAI.

**PERSONAL SAFETY**

Electrical or mechanical misapplication of electrolytic capacitors may be hazardous. Personal injury or property damage may result from explosion of a capacitor or from the expulsion of electrolyte due to mechanical disruption or the release of a safety vent of a capacitor. In case of injury or skin or eye exposure to electrolyte, immediately seek professional medical advice. Before using electrolytic capacitors in any application, please read these Handling Precautions, familiarizing thoroughly with the information contained herein. Please check before using any of our electrolytic capacitors if these components fulfill the requirements of your application and that warnings and instructions for use are followed.

**WARRANTY**

The information contained in this catalogue does not form part of any quotation or contract, is believed to be accurate, reliable and up to date. Quality data are based on the statistical evaluations of a large quantity of parts and do not constitute a guarantee in a legal sense. However, agreement on these specifications does mean that the customer may claim for replacement of individual defective capacitors within the terms of delivery. We will not assume any liability beyond the replacement of defective components. This applies in particular to any consequential damage caused by component failure. Furthermore it must be taken into consideration that the figures stated for lifetime, failure rates and outlier percentages refer to the average production status and are therefore to be understood as mean values (statistic expectations) for a large number of delivery lots of identical capacitors. These figures are based on application experience and data obtained from preceding tests under normal conditions, or – for purpose of accelerated aging – more severe conditions. JIANGHAI reserves the right to change these specifications without prior notice. Any application information given is advisory and does not form part of any specification. The products are not primarily designed for use in life support applications, devices or systems where malfunction of these products can reasonably be expected to result in personal injury. JIANGHAI customers using or selling these products for use in such applications without prior written consent of JIANGHAI do so at their own risk and agree fully to indemnify JIANGHAI for any damage resulting from such improper use or sale. This version of the catalogue supersedes all previous versions. Latest versions of datasheets can be found on our homepage: [www.jianghai-europe.com](http://www.jianghai-europe.com). For more details on precautions and guidelines for aluminum electrolytic capacitors, please refer to CENELEC Technical Report CLC/TR 50454:2008 E, "Guide for the application of aluminum electrolytic capacitors".

**POLARITY**

Electrolytic capacitors are polar and shall never be used with incorrect polarity, as there is a possible danger of shorting or destruction.

**RATED VOLTAGE  $U_R$**

The rated voltage is marked on the capacitor and defined in the datasheets as  $U_R$ . This voltage should never be exceeded and is the maximum peak voltage including any ripple voltages allowed to avoid a shortening of the lifetime or damage of the capacitor. When a ripple current is applied to the capacitor, the sum of the peak ripple voltage and bias DC voltage shall never exceed the rated voltage. It might be necessary to lower the maximum allowed bias DC voltage, when certain ripple currents are applied to the capacitor.

**SURGE VOLTAGE**

Maximum voltage, which may be applied to the capacitor for short periods of time: max. 1000 cycles of 30 sec. per 6 min., max. 5 pulses per hour. Capacitance drift +/- 15% max.

**REVERSE VOLTAGE**

Reverse voltages or voltages < 0V are not allowed.





## RECOVERY VOLTAGE

Electric potential between the positive and negative terminal may exist as a result of dielectric absorption. Please take action that this load does not damage other devices or scare workers during the production process (sparks possible). If needed please discharge the capacitor through a 1kΩ resistor.

## TEMPERATURE RANGE

Use electrolytic capacitors only within the specified operating temperature range.

## OVER-CURRENT

Currents exceeding the rated ripple currents should be avoided.

## RIPPLE CURRENT/VOLTAGE

The combined value of DC voltage and peak AC voltage (due to ripple current) shall not exceed the rated voltage and shall never be < 0V. Use of aluminum electrolytic capacitors under ripple current with wide amplitudes is equivalent to rapid charge-discharge operation.

## RAPID CHARGING/DISCHARGING

Rapid charging/discharging generates severe heat and gas may be emitted which may lead to explosion. Consult JIANGHAI about specially designed capacitors suitable for such kind of applications. Example: Servo Drive Application

## BALANCING RESISTORS

Balancing resistors should be utilized if capacitors are used in serial connection. Please choose low-tolerance resistors to limit voltage drift.

## CHARGE-DISCHARGE PROOF

JIANGHAI capacitors are charge-discharge proof, which means that 10<sup>6</sup> switching cycles will cause capacitance reduction of less than 10%.

## LIFETIME

There are many different lifetime definitions known without any true standard definition. Take special care when capacitors are compared that the capacitors fulfill the needed requirements. JIANGHAI publishes all conditions to be as transparent as possible. In the case of lifetime tests with additional ripple currents, the bias DC voltage must be reduced, so that the sum of bias DC voltage and the peak of the ripple voltage does not exceed the Rated Voltage  $U_R$ .

**Load life:** Period of time, during which the technical parameters of all capacitors stay within the given limits. JIANGHAI defines this without allowing for outliers.

**Useful life:** Defined like load life, but with a larger range of parameter change.

**Endurance test:** IEC 60384-4 defines the acceptable drift criteria of electrical parameters after the endurance tests (continuous voltage test).

**Shelf Life:** Definition of time with acceptable drift of capacitor parameters after storage at upper category temperature without load.

## VIBRATION AND MECHANICAL STRESS

Capacitors are sensitive to vibration and mechanical forces applied on the leads. Do not use capacitors, which have been dropped onto a rigid surface.

## INSULATION

If any defect of the sleeve is visible, the component should not be used – the same holds for any kind of visible damage. A capacitor should be electrically isolated from the following parts: aluminum case, cathode lead wire, anode lead wire and circuit pattern, and auxiliary terminal of snap-in type. The sleeve is not recognized as an isolator and therefore the standard capacitor should not be used in a place where insulation function is needed. Please contact JIANGHAI if a higher grade of insulation is required.

## ENVIRONMENTAL CONDITIONS

Avoid direct contact with water, salt solution, oil, dewing conditions. Halogens generally, especially fumigation treatment with bromides and flame retardant agents containing halogens must be avoided. Avoid exposing to direct sunshine, ozone, ultraviolet rays and x-ray radiation. Air Pressure: Max. 150kPa, min. 8kPa. For usage >2000m altitude above sea level current deratings might be necessary. No heavy air pressure changes are allowed. Do not use or store in an environment containing any hazardous gas (e.g., hydrogen sulphide, sulphurous acid, nitrous acid, chlorine, ammonia, bromine, methyl bromide, other halogens) or acidic or alkaline solutions.

## STORAGE

Temperature 5 to 35°C, relative humidity below 75%. Electrolytic capacitors may accumulate charge naturally during storage. In this case discharge through a 1kOhm resistor before use (Recovery voltage). Leakage current may be increased after long storage time. In this case the capacitor should be subjected to the rated voltage treatment through a 1kOhm resistor before use for 1 hour, then it should be discharged through a resistor of about 1 Ohm/Volt. Storage times above 1 year should be avoided or rated voltage treatment may be necessary. In accordance to IEC 60384-4 electrolytic capacitors are subject to a reforming process before acceptance testing. Rated voltage is applied via a series resistance (100Ω:  $U_R \leq 100VDC$ , 1kΩ:  $U_R > 100VDC$ ).

## SOLDERING

Soldering conditions (temperature, times) should be within specified conditions, especially for SMD components. Avoid high soldering temperatures as this may reduce lifetime or damage the capacitor. Do never dip the capacitor body into molten solder. Flux should not be adhered to the capacitor's body but only to its terminals. For details and different methods please contact us.

## GLUEING, CLEANING AND COATING

Do not use fixing agents or cleaning substances containing halogens. Do not use coating and moulding components that completely seal the capacitor from the environment. Also, never use solvents containing: halogenated hydrocarbons, alkali, petroleum, trichloroethylene/-ethane, xylene, acetones, trichlorotrifluoroethane, tetrachloroethylene, methylenechloride, chloroform, acetates, ketones, esters, chlorides and bromides.

## MOUNTING

Other devices, which are mounted near the capacitor, should not touch the capacitor. Additional heat coming from other components near the capacitor may reduce the lifetime of the capacitor. Do never bend or twist the capacitor after soldering to avoid stress on the leads. Radial capacitors are not protected against mechanical forces on the leads. Forces on the pins might damage the capacitor. No printed circuit board tracks are allowed between the lead pads of the capacitor. Screw Terminal capacitors should only be mounted in an upright position.

## TRANSPORT

Avoid fumigation and spraying insecticides (especially with bromides) in the import or export procedures which can cause corrosion. This applies also to the finished devices.

## MAINTENANCE

Periodical inspection should be carried out for the capacitor: visual inspection to check pressure relief open or leakage of electrolyte, electrical characteristics as leakage current, capacitance, and dissipation factor.

## ELECTROLYTE AND SEPARATOR PAPER

Electrolyte and separator paper used in aluminum capacitors may be flammable. Also, electrolyte is electrically conductive. Therefore, in case electrolyte gets in contact with PC board it may cause corrosion of circuit pattern or cause short circuit between patterns, and may lead to smoke generation or ignition in worst case.

## CAUTION DURING USE OF CAPACITORS

Do not touch the terminals of capacitors. Keep the capacitor free from conductive solution, such as acids, alkali and so on. Ensure that the operating environment of the equipment into which the capacitor has been built is within the specified conditions mentioned in the catalogue or specification sheets.

## SAFETY VENT

The safety vent needs some free space to open properly. Allow for free headroom of at least 2mm for diameter ≤16mm, more than 3mm for diameter 18-35mm, more than 5mm for case diameter 40mm and larger.

## EMERGENCY ACTIONS

When the pressure relief vent is open and some gas blows out from the capacitor, please turn the main switch of the equipment off or pull out the plug from the power outlet immediately. During safety vent operation, extremely hot gas (>100°C) may blow out of the capacitors. Do not stand close to the capacitors. In case of eye contact, rinse the open eye(s) with clean water immediately. In case of ingestion, gargle with water immediately, do not swallow. Do not touch electrolyte but wash skin with soap and water in case of skin contact.

## DEFINITION OF ELECTRICAL PARAMETERS

Separate documents as application notes, equivalent circuit diagrams and so on are available on request.

## PACKAGING

Please refer to the data book for details. Further information is available on request.

## DISPOSAL

Scrapped capacitors are classified as scrapped metal. For disposal they are handled as controllable industrial waste because of the nature of the contents (electrolyte). Most of the material is aluminum and cannot be completely burned.

*Jianghai Europe Electronic Components GmbH*

*VERSION 10/2021*

