

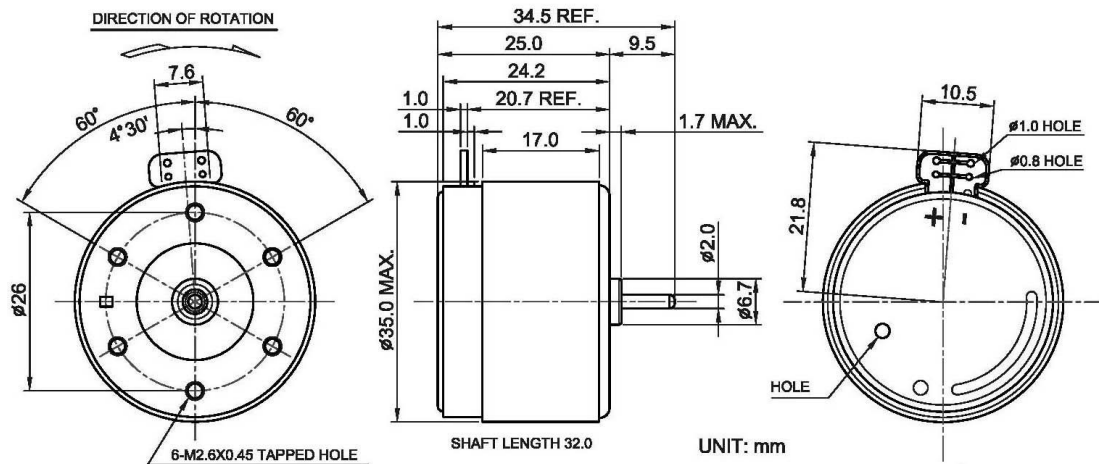

Typical Application:

1. Audio and Visual Equipments
2. Car Cassette Tape Recorder

Weight: 50g (Approx.)



* Electronic Governor DC Motor

ELECTRICAL SPECIFICATION CHART: (The following specifications can be changed as customers' requirement)

MODEL	RATED VOLTAGE	WORKING VOLTAGE	RATED LOAD		RATED SPEED	RATED LOAD CURRENT	LOAD FLUCTUATION	STARTING TORQUE (MIN)	
	V	V	g-cm	mN-m	rpm	mA (TYP)	rpm/ g-cm (YTP)	g-cm	mN-m
EG530A-6F(6B)	6	4.2-7.5	8.0	0.78	2400	132	9.0	38at4.2V	3.77at4.2V
EG530A-9F(9B)	9	6.0-11	8.0	0.78	2400	92	9.0	50at6.0V	4.90at6.0V
EG530A-2F(2B)	12	8.4-15	8.0	0.78	2400	73	9.0	60at8.4V	5.88at8.4V
EG530Y-9BH	9	6.3-11.7	10	0.98	2000	128	1.5	50	4.90
					4000	140	4.0		
EG530Y-2BH	12	8.4-15.6	10	0.98	2000	99	1.5	55	5.39
					4000	108	4.0		

CHARACTERISTIC CURVES:

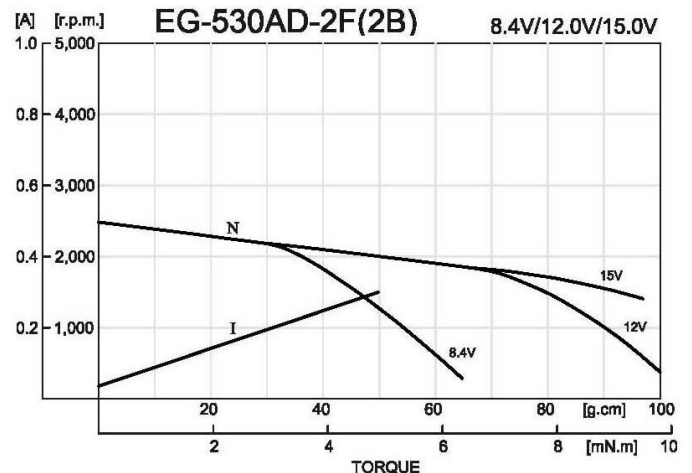
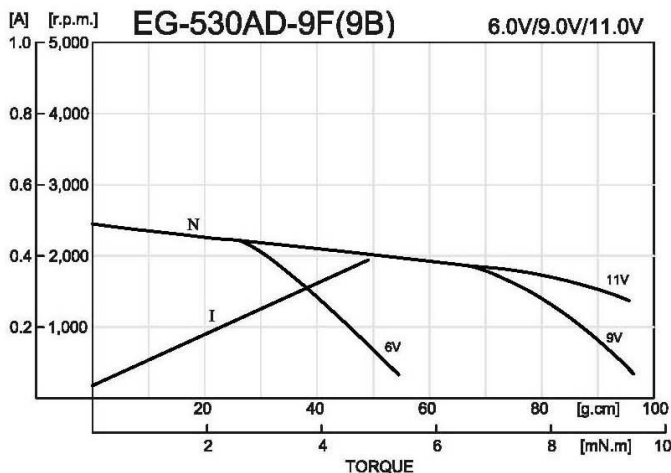

Shenzhen Nostop Electric Co., Ltd

Building C#, Gangzhilong Science & Technology Industrial Park, Qinglong Road, Longhua Town,
Shenzhen City, Guangdong Province, 518107 P.R.China

TEL: +86.755. 2983 4766, 2815 9775, 2815 9776 FAX: +86.755. 2967 4299

E-mail: stony@nostop.cn

URL: <http://www.nostopmotor.com>, <http://www.nostop.cn>