

**Features:**

\* Carbon Brush Motor.

**Weight:**

160g (APPROX)

**Typical Application:**

Vacuum Cleaner, Air Compressor, Drills &amp; Screwdrivers, Cordless Tools, Radio Control Models, Toys and Models

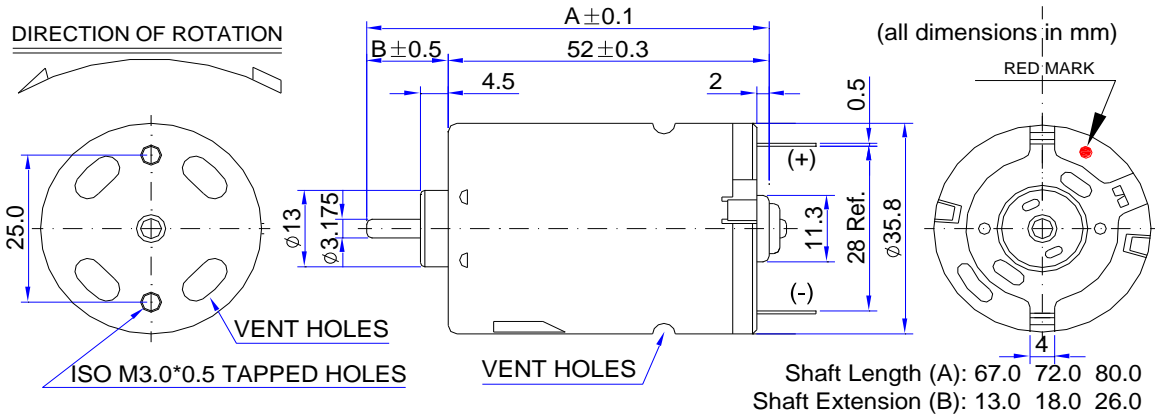
**ELECTRICAL SPECIFICATION :** (The following specifications can be changed as customers' requirement)

Model	Voltage		At No Load		At Max Efficiency					Stall Torque
	Workable Range	Nominal	Speed	Current	Speed	Current	Torque	Output	Eff.	G.CM
			RPM	A	RRPM	A	G.CM	W	%	
RC540PM-10009	3.0~12.0	3.6V Constant	22560	3.33	16560	12.50	200	33.9	75.3	754
RC540PM-5045	9.0~24.0	12V Constant	16600	0.70	14370	4.59	290	42.7	77.5	2160
RC540PM-6035	4.5~15.0	12V Constant	22400	1.30	19100	6.00	300	58.7	81.5	2036
RC540PM-6530	3.6~7.2	7.2V Constant	16000	1.17	12100	10.30	300	37.2	50.2	2190
RC540PM-7030	6.0~12.0	12V Constant	26100	1.60	22075	7.59	350	79.2	86.9	2269
<b>RC540PM-7515</b>	<b>3.0~9.0</b>	<b>6.0V Constant</b>	<b>23100</b>	<b>2.60</b>	<b>19500</b>	<b>14.08</b>	<b>280</b>	<b>56.0</b>	<b>66.3</b>	<b>1798</b>
RC540PM-7522	3.0~9.0	6.0V Constant	16500	1.70	14300	5.56	200	29.3	87.6	1500

**CHARACTERISTIC CURVES:**
