



Features:
* Carbon Brush Motor.

Weight:
215g (APPROX)

Typical Application:

1. Printer, Computer Peripherals, Drill, Screwdriver, Lumber Support, etc.
2. Car Antenna, Air Compressor, Coreless Garden Tools.

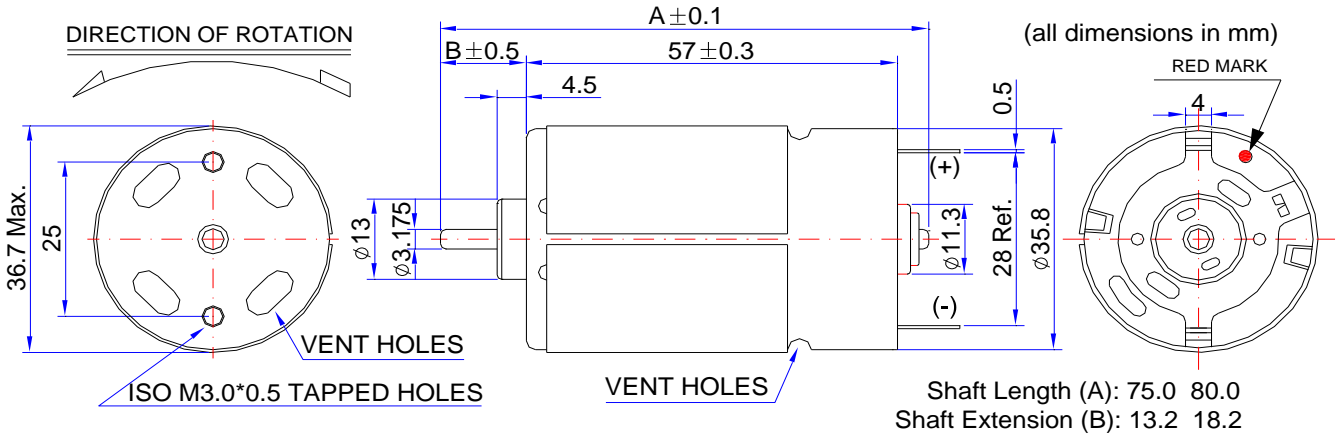

ELECTRICAL SPECIFICATION CHART: (The specifications can be changed as customers' requirement)

Model	Voltage		At No Load		At Max Efficiency					Stall Torque G.CM
	Workable Range	Nominal	Speed RPM	Current A	Speed RRPM	Current A	Torque G.CM	Output W	Eff. %	
RC550PM-5632	3.0~24V	15.6V Constant	21300	1.20	18266	7.46	460	86.2	74.0	3232
RC550PM-5634	6~30V	16.8V Constant	21500	1.18	18500	7.73	520	99.1	76.3	3840
RC550PM-5636	6~24V	18.0V Constant	21800	1.14	18780	8.10	520	100.2	68.7	3736
RC550PM-6526	12~20V	12.0V Constant	20000	1.46	17148	8.85	420	73.9	69.5	2945
RC550PM-6528	12~20V	13.2V Constant	20000	1.36	17143	8.44	460	80.9	72.6	3220
RC550PM-6530	12~20V	14.4V Constant	20800	1.32	17630	7.64	430	77.7	70.6	2822
RC550PM-7017	6.0~15V	7.2V Constant	17800	2.00	15160	11.2	370	57.5	71.3	2493

CHARACTERISTIC CURVES:

