

**Features:**

\* Carbon Brush Motor.

**Weight:**

350g (APPROX)

**Typical Application:**

1. Cordless Power Tools : Drills & Screwdrivers
2. Office Automation Equipments: Printer / Cordless Garden Tools

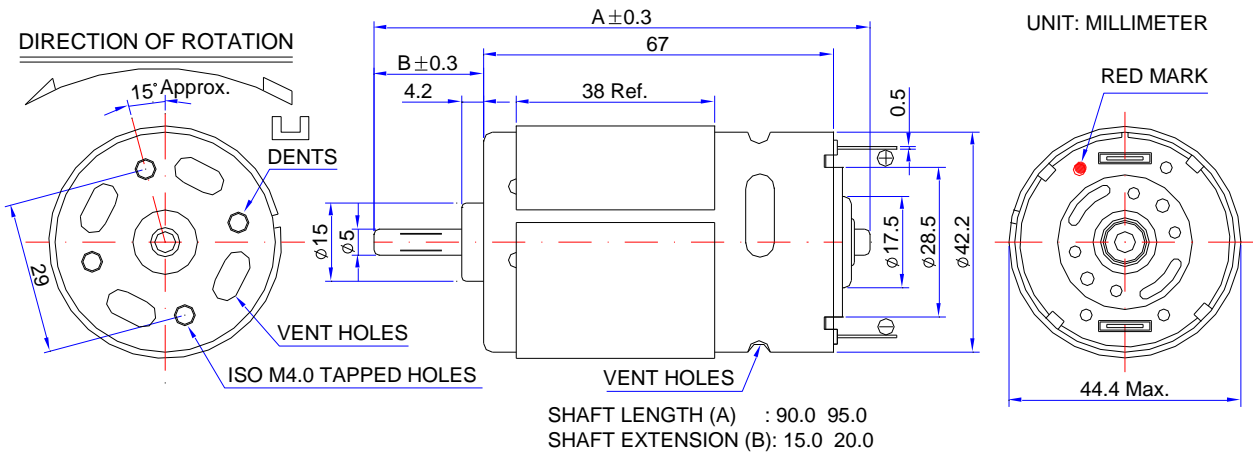
**ELECTRICAL SPECIFICATION CHART: (The specifications can be changed as customers' requirement)**

Model	Voltage		At No Load		At Max Efficiency					Stall Torque GCM
	Workable Range	Nominal	Speed	Current	Speed	Current	Torque	Output	Eff.	
			RPM	A	RRPM	A	GCM	W	%	
RC775PM-2765	6~30.0V	24.0V Constant	7600	0.37	5810	2.22	750	44.7	83.0	3186
<b>RC775PM-27100</b>	<b>6~30.0V</b>	<b>24.0V Constant</b>	<b>4264</b>	<b>0.26</b>	<b>3479</b>	<b>1.25</b>	<b>530</b>	<b>18.9</b>	<b>63.0</b>	<b>2892</b>
RC775PM-3848	6~30.0V	24.0V Constant	8600	0.55	7310	3.33	750	56.3	70.4	5000
RC775PM-4040	6~15.0V	12.0V Constant	5000	0.55	4199	2.94	460	19.8	56.1	2880
RC775PM-4045	6~15.0V	12.0V Constant	4600	0.60	3500	4.30	860	36.6	70.9	3600
RC775PM-5026	6~12.0V	12.0V Constant	8300	1.00	7050	5.68	650	47.0	69.0	4318
RC775PM-5036	6~12.0V	12.0V Constant	6000	0.70	4800	4.86	800	40.0	68.6	4000
RC775PM-7513	6~12.0V	12.0V Constant	18700	2.20	16000	13.60	710	116.5	71.4	5100

**CHARACTERISTIC CURVES:**
